



WiMAX Forum[®] Network Architecture

System Requirements, Network Protocols and Architecture
for Multi-cast Broad-cast Services

(MCBCS Application Layer Approach)

WMF-T33-113-R015v01

WiMAX Forum[®] Approved

(2009-11-21)

WiMAX Forum Proprietary

© 2007-2009 WiMAX Forum. All Rights Reserved.

Copyright Notice, Use Restrictions, Disclaimer, and Limitation of Liability.

Copyright 2007-2009 WiMAX Forum. All rights reserved.

The WiMAX Forum® owns the copyright in this document and reserves all rights herein. This document is available for download from the WiMAX Forum and may be duplicated for internal use, provided that all copies contain all proprietary notices and disclaimers included herein. Except for the foregoing, this document may not be duplicated, in whole or in part, or distributed without the express written authorization of the WiMAX Forum.

Use of this document is subject to the disclaimers and limitations described below. Use of this document constitutes acceptance of the following terms and conditions:

THIS DOCUMENT IS PROVIDED “AS IS” AND WITHOUT WARRANTY OF ANY KIND. TO THE GREATEST EXTENT PERMITTED BY LAW, THE WiMAX FORUM DISCLAIMS ALL EXPRESS, IMPLIED AND STATUTORY WARRANTIES, INCLUDING, WITHOUT LIMITATION, THE IMPLIED WARRANTIES OF TITLE, NONINFRINGEMENT, MERCHANTABILITY AND FITNESS FOR A PARTICULAR PURPOSE. THE WiMAX FORUM DOES NOT WARRANT THAT THIS DOCUMENT IS COMPLETE OR WITHOUT ERROR AND DISCLAIMS ANY WARRANTIES TO THE CONTRARY.

Any products or services provided using technology described in or implemented in connection with this document may be subject to various regulatory controls under the laws and regulations of various governments worldwide. The user is solely responsible for the compliance of its products and/or services with any such laws and regulations and for obtaining any and all required authorizations, permits, or licenses for its products and/or services as a result of such regulations within the applicable jurisdiction.

NOTHING IN THIS DOCUMENT CREATES ANY WARRANTIES WHATSOEVER REGARDING THE APPLICABILITY OR NON-APPLICABILITY OF ANY SUCH LAWS OR REGULATIONS OR THE SUITABILITY OR NON-SUITABILITY OF ANY SUCH PRODUCT OR SERVICE FOR USE IN ANY JURISDICTION.

NOTHING IN THIS DOCUMENT CREATES ANY WARRANTIES WHATSOEVER REGARDING THE SUITABILITY OR NON-SUITABILITY OF A PRODUCT OR A SERVICE FOR CERTIFICATION UNDER ANY CERTIFICATION PROGRAM OF THE WiMAX FORUM OR ANY THIRD PARTY.

The WiMAX Forum has not investigated or made an independent determination regarding title or noninfringement of any technologies that may be incorporated, described or referenced in this document. Use of this document or implementation of any technologies described or referenced herein may therefore infringe undisclosed third-party patent rights or other intellectual property rights. The user is solely responsible for making all assessments relating to title and noninfringement of any technology, standard, or specification referenced in this document and for obtaining appropriate authorization to use such technologies, technologies, standards, and specifications, including through the payment of any required license fees.

NOTHING IN THIS DOCUMENT CREATES ANY WARRANTIES OF TITLE OR NONINFRINGEMENT WITH RESPECT TO ANY TECHNOLOGIES, STANDARDS OR SPECIFICATIONS REFERENCED OR INCORPORATED INTO THIS DOCUMENT.

IN NO EVENT SHALL THE WiMAX FORUM OR ANY MEMBER BE LIABLE TO THE USER OR TO A THIRD PARTY FOR ANY CLAIM ARISING FROM OR RELATING TO THE USE OF THIS DOCUMENT, INCLUDING, WITHOUT LIMITATION, A CLAIM THAT SUCH USE INFRINGES A THIRD PARTY’S INTELLECTUAL PROPERTY RIGHTS OR THAT IT FAILS TO COMPLY WITH APPLICABLE LAWS OR REGULATIONS. BY USE OF THIS DOCUMENT, THE USER WAIVES ANY SUCH CLAIM AGAINST THE WiMAX FORUM AND ITS MEMBERS RELATING TO THE USE OF THIS DOCUMENT.

The WiMAX Forum reserves the right to modify or amend this document without notice and in its sole discretion. The user is solely responsible for determining whether this document has been superseded by a later version or a different document.

“WiMAX,” “Mobile WiMAX,” “Fixed WiMAX,” “WiMAX Forum,” “WiMAX Certified,” “WiMAX Forum Certified,” the WiMAX Forum logo and the WiMAX Forum Certified logo are trademarks of the WiMAX Forum. Third-party trademarks contained in this document are the property of their respective owners.

1	TABLE OF CONTENTS	
2	1. REVISION HISTORY.....	6
3	2. MCBCS NETWORK REFERENCE MODEL.....	7
4	2.1 Overview of MCBCS Network Reference Model.....	7
5	2.2 MCBCS Specifics at Reference Points.....	9
6	3. DATA PLANE.....	10
7	3.1 Data Path for MCBCS.....	10
8	3.2 Protocol Stack.....	11
9	3.3 Transport on R3.....	11
10	3.4 Transport on R6.....	12
11	3.4.1 Packetization.....	12
12	3.4.2 GRE Encapsulation.....	12
13	3.4.3 IP Routing.....	14
14	3.5 Transport on R1.....	15
15	4. FUNCTIONAL DESIGN AND DECOMPOSITION.....	16
16	4.1 High Level Control Flow Information.....	16
17	4.2 Service Provisioning Procedures.....	18
18	4.2.1 MCBCS Service Discovery.....	18
19	4.2.1.1 Server Discovery.....	18
20	4.2.1.2 Service Announcement/Service Guide Delivery.....	18
21	4.2.1.3 Combined Message IEs.....	19
22	4.2.2 Subscription and Unsubscription.....	20
23	4.2.2.1 Subscription.....	20
24	4.2.2.2 Combined Message IEs.....	22
25	4.2.2.3 Unsubscription.....	26
26	4.2.2.4 Combined Message IEs.....	27
27	4.2.3 Service Announcement.....	28
28	4.2.4 Joining Service.....	28
29	4.2.5 Session Start.....	29
30	4.2.5.1 MCBCS Data Path Creation.....	29
31	4.2.5.2 Combined Message IEs.....	30
32	4.2.5.3 Error Handling During MCBCS Data Path Creation.....	35
33	4.2.5.3.1 MCBCS Data Path Creation Failure under All BSs.....	35
34	4.2.5.3.2 Combined Message IEs.....	36
35	4.2.5.3.3 Timers and Timing Considerations.....	37
36	4.2.5.3.4 Handling Error Conditions.....	37
37	4.2.5.3.5 Timer Expiry.....	39
38	4.2.6 Session Stop.....	40
39	4.2.6.1 MCBCS Data Path Release.....	40
40	4.2.6.2 Combined Message IEs.....	41
41	4.2.6.3 Error Handling During MCBCS Data Path Release.....	43
42	4.2.6.3.1 Timers and Timing Considerations.....	43
43	4.2.6.3.2 Handling Error Conditions.....	44
44	4.2.6.3.3 Timer Expiry.....	44
45	4.2.7 Leaving Service.....	45
46	4.2.8 Delivery Confirmation and Unicast Retransmission.....	46
47	4.2.8.1 Combined Message IEs.....	47
48	4.3 Mobility Management.....	49
49	4.4 Power Saving Support.....	49

MCBCS-Applayer

1 4.4.1 Mobile Station operation for MCBCS 50

2 4.5 Security 50

3 4.5.1 Group Management 50

4 4.5.1.1 Group Management Procedures 50

5 4.5.2 Session Management 51

6 4.5.2.1 Session Management mechanism 51

7 4.6 MCBCS QoS 51

8 4.7 Accounting 52

9 4.7.1 Subscription Based Accounting 52

10 4.7.2 Traffic Based Accounting 53

11 4.7.3 Time Based Accounting 55

12 4.8 Roaming Support 55

13 4.9 MCBCS Network Resource Management 55

14 4.9.1 MCBCS Radio Resource Management 56

15 4.9.2 Multi-BS Transmission Synchronization 56

16 4.10 Transport Mechanism for Content Delivery 56

17 4.10.1 Via Unicast 56

18 4.10.2 Via Multicast and Broadcast 56

19 **5. GENERIC PROCEDURES TO SUPPORT THE DATA TRANSFER 57**

20 5.1 Real time data transfer over Broadcast Channel 57

21 5.1.1 Protocol stack 57

22 5.1.2 Procedures for real time data transfer over Broadcast Channel 57

23 5.2 Non Real time data transfer over Broadcast Channel 57

24 5.2.1 Protocol stack 57

25 5.2.2 Procedures for non real time data transfer over Broadcast Channel 57

26 5.3 Non scheduled data transfer over Broadcast Channel 57

27 5.3.1 Protocol stack 58

28 5.3.2 Procedures for non scheduled data transfer over Broadcast Channel 58

29 5.3.2.1 Idle Mode MCBCS Support with Alert 58

30 5.3.2.2 Sleep Mode MCBCS Support with Alert 58

31 **6. MESSAGE AND PARAMETER DEFINITIONS 59**

32 6.1 Message Definitions and Construction Rule 59

33 6.2 TLV Definitions 60

34 6.2.1 TLV Format 60

35 6.2.2 TLV Encoding 60

36 6.2.2.1 Contents ID 60

37 6.2.2.2 Contents Info 60

38 6.2.2.3 Contents IP 60

39 6.2.2.4 Contents Type 61

40 6.2.2.5 Delivery End Time 61

41 6.2.2.6 Delivery Start Time 61

42 6.2.2.7 GRE Key 61

43 6.2.2.8 MBS Zone ID 62

44 6.2.2.9 MBS Zone Info 62

45 6.2.2.10 MCID 62

46 6.2.2.11 R6 Multicast IP 63

47 6.2.2.12 MBS DPF ID 63

48 6.2.2.13 Macrodiversity-enabled 63

49 6.2.2.14 MCID Reservation Result 63

50

51

1 LIST OF FIGURES

2 FIGURE 2-1 - MCBCS NETWORK REFERENCE MODEL.....7

3 FIGURE 3-1 - OVERVIEW OF MCBCS DATA PATH.....10

4 FIGURE 3-2 - PROTOCOL STACK FOR TYPE-4 MCBCS DATA PLANE.....11

5 FIGURE 3-3 - TYPE-4 MCBCS DATA TRANSFER.....12

6 FIGURE 3-4 - SYNC INFO HEADER FORMAT.....13

7 FIGURE 3-5 - GRE HEADER FORMAT14

8 FIGURE 4-1 - CONTROL FLOW16

9 FIGURE 4-2 - SERVICE GUIDE ACQUISITION.....18

10 FIGURE 4-3 - ONLINE SUBSCRIPTION PROCEDURE21

11 FIGURE 4-4 - ONLINE UNSUBSCRIPTION PROCEDURE.....26

12 FIGURE 4-5 - MS INTERNAL OPERATION28

13 FIGURE 4-6 - MCBCS DATA PATH CREATION PROCEDURE29

14 FIGURE 4-7 - MCBCS DATA PATH CREATION FAILURE UNDER ALL BSS.....35

15 FIGURE 4-8 - MCBCS DATA PATH RELEASE PROCEDURE40

16 FIGURE 4-9 - DELIVERY CONFIRMATION PROCEDURE46

17 FIGURE 4-10 - GROUP MANAGEMENT PROCEDURES (EXAMPLE).....50

18 FIGURE 4-11 - CALL FLOW FOR SUBSCRIPTION BASED ACCOUNTING52

19 FIGURE 4-12 - CALL FLOW FOR TRAFFIC BASED ACCOUNTING54

20

21

1 **LIST OF TABLES**

2 TABLE 2-1 - MCBCS SPECIFICS.....9

3 TABLE 3-1 - SYNC INFO HEADER FIELD DEFINITION13

4 TABLE 3-2 - GRE HEADER FIELD DEFINITION14

5 TABLE 4-1 - SERVICE GUIDE REQUEST19

6 TABLE 4-2 - SERVICE GUIDE RESPONSE19

7 TABLE 4-3 - SUBSCRIPTION REQUEST22

8 TABLE 4-4 - SUBSCRIPTION RESPONSE22

9 TABLE 4-5 - UNSUBSCRIPTION REQUEST27

10 TABLE 4-6 - UNSUBSCRIPTION RESPONSE27

11 TABLE 4-7 - R6_MBS_PATH_REG_REQ30

12 TABLE 4-8 - R6_MBS_PATH_REG_RSP32

13 TABLE 4-9 - R3_SESSION_START_REQ32

14 TABLE 4-10 - R3_SESSION_START_RSP34

15 TABLE 4-11 - R3_SESSION_FAILURE_IND36

16 TABLE 4-12 - R3_SESSION_FAILURE_ACK37

17 TABLE 4-13 - TIMER VALUES FOR MCBCS PATH CREATION PROCEDURE37

18 TABLE 4-14 - MCBCS DATA PATH CREATION – HANDLING ERROR CONDITIONS38

19 TABLE 4-15 - TIMER MAX RETRY CONDITIONS39

20 TABLE 4-16 - R6_MBS_PATH_DEREG_REQ41

21 TABLE 4-17 - R6_MBS_PATH_DEREG_RSP41

22 TABLE 4-18 - R3_SESSION_REL_REQ42

23 TABLE 4-19 - R3_SESSION_REL_RSP43

24 TABLE 4-20 - TIMER VALUES FOR MBS PATH RELEASE PROCEDURE43

25 TABLE 4-21 - MCBCS DATA PATH RELEASE – HANDLING ERROR CONDITIONS44

26 TABLE 4-22 - TIMER MAX RETRY CONDITIONS44

27 TABLE 4-23 - DELIVERY CONFIRMATION NOTIFICATION47

28 TABLE 4-24 - DELIVERY CONFIRMATION RESPONSE47

29 TABLE 4-25 - UNICAST RETRANSMISSION REQUEST48

30 TABLE 4-26 - UNICAST RETRANSMISSION RESPONSE48

31 TABLE 6-1 - FUNCTION AND MESSAGE TYPES INDEX59

32

33

34

1

2

1. Revision History

3

November 6, 2009	Initial version of Release 1.5.
------------------	---------------------------------

2. MCBCS Network Reference Model

2.1 Overview of MCBCS Network Reference Model

This section describes the system functional components that are required to support MCBCS over a WiMAX network.

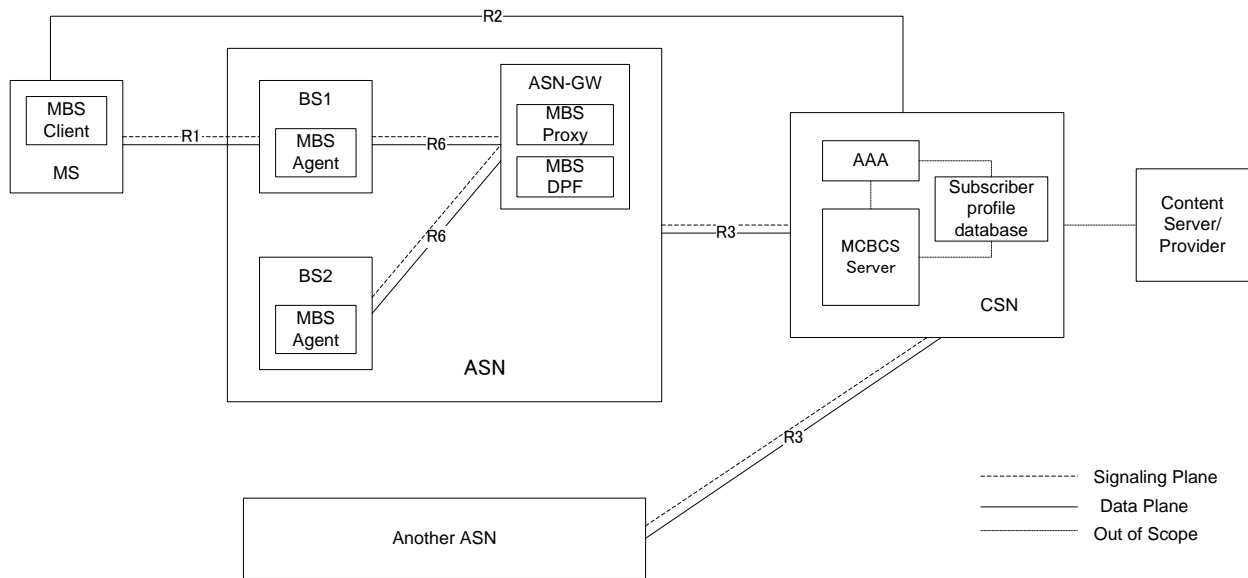

Figure 2-1 - MCBCS Network Reference Model

- MCBCS Content Server:

MCBCS Content Server provides the content of MCBCS services, like multimedia flows, data files, etc. The content provider can belong to the NSP or be a third party outside the WiMAX network. The interface between MCBCS Server function and Content Server is outside the scope of this specification.

MCBCS Functions in CSN

- MCBCS Server:

MCBCS server is a network entity, which hosts all MCBCS specific functional components in the CSN. It performs the following functions:

- IP multicast group management
- MCBCS program management
- MCBCS service announcement management including MCBCS service guide manipulation and distribution.
- MCBCS session management
- Data encryption support
- Application layer key management

- 1 ➤ Security association between MCBCS Server and MBS Client
- 2 ➤ Delivery of the mapping information for the MCBCS content's IP address to the MCID per MBS Zone, and
- 3
- 4 ● AAA
- 5 ➤ This entity is responsible for MCBCS authentication, authorization, and accounting. It accesses the
- 6 Subscriber Profile Repository to obtain information.
- 7
- 8 ● Subscriber Profile Repository:
- 9 ➤ Store and manage subscriber profiles.
- 10 ➤ The interface between subscriber profile repository, AAA, and MCBCS server is outside the scope of this
- 11 document. Subscriber profile repository may be the same as the one used for unicast services.
- 12

13 **MCBCS Entities and Functions in NAP**

- 14
- 15 ● MBS Proxy:
- 16 MBS Proxy is a control plane function in the NAP to support MCBCS service. It is unique per MBS zone:
- 17 ➤ Interact with MCBCS Server to support MCBCS session management.
- 18 ➤ Relaying bearer establishment request from MCBCS Server to MBS DPF
- 19 ➤ Interact with the MBS DPF to support service synchronization for DL macro diversity.
- 20 ➤ Interface with the MBS DPF to trigger the MCBCS data path establishment and release
- 21
- 22 ● MBS DPF:
- 23 The MBS DPF function is a data plane entity in the NAP. It is responsible for data plane bearer management and
- 24 MCBCS data distribution. MBS DPF is unique per MBS zone. MBS DPF distribution between ASNs over R4 is
- 25 not assumed.
- 26 ➤ MCBCS bearer control management including the data path establishment, maintenance, and release.
- 27 ➤ MCBCS bearer traffic classification & delivery
- 28 ➤ GRE key management and distribution.
- 29 ➤ After receiving session start trigger from MBS Proxy, act as an IGMP client to send IGMP report message for
- 30 IPv4 (act as a MLD client to send MLD report message for IPv6) to the last MR between ASN and CSN to
- 31 join IP multicast group tree between ASN and CSN
- 32 ➤ Performing time stamping and packetization (fragmentation and packing) over the single frequency and
- 33 multi-frequency WiMAX networks.
- 34 ➤ Forwarding IP multicast packet
- 35 ● MBS Agent
- 36 MBS Agent includes the collection of MCBCS specific functions of ASN which are located at the BS. MBS
- 37 Agent is a functional entity responsible for data plane bearer management and providing the resource allocation
- 38 information to support the macro diversity
- 39 ➤ Support DPF functions at the BS

MCBCS-Applayer

- 1 ➤ Construct the MBS subframe based on the information configured by NAP and the sync information included
- 2 in each SDU, and then transmit over the air.
- 3 ➤ Broadcast MBS_MAP_IE, MBS_MAP and MBS_DATA_IE including MBS zone ID and MCID
- 4
- 5 ● MBS Client
- 6 MBS Client represents functionality required in the MS for MCBCS service reception. MBS client implements
- 7 the following functions:
- 8 ➤ Compliant to IEEE 802.16 standard as much as possible .
- 9 ➤ IP multicast capable IPv4 and IPv6 stack
- 10 ➤ Application layer – Application client at the application layer may be responsible among others for the
- 11 following functions:
- 12 ● Service discovery/announcement
- 13 ● Service subscription/registration
- 14 ● Application layer security (if required)
- 15 ● Optional statistic collection support
- 16 ● Reconstruct the MCBCS program content
- 17

2.2 MCBCS Specifics at Reference Points

Table 2-1 - MCBCS Specifics

Reference point	Functions
R1	✓ 802.16e support
R2	<ul style="list-style-type: none"> ✓ Support of Subscription ✓ Service Guide Distribution ✓ Key delivery ✓ Support of Notification ✓ Support of Reception Report
R3	<ul style="list-style-type: none"> ✓ Notification on session start ✓ Bearer establishment/release ✓ Multicast support
R6	<ul style="list-style-type: none"> ✓ Bearer establishment/release ✓ Multicast support over R6 ✓ Transfer synch. Information, data

20

3. Data Plane

3.1 Data Path for MCBCS

The data path for MCBCS is established between MCBCS Server and ASN-GW, and between ASN-GW and BSs. The direction of the data path is downlink only.

The data path isn't dedicated to each user but shared by all users. The granularity of the data path shall be multicast IP on R3 interface and {MBS Zone ID, MCID} pair on R6 interface.

Overview of MCBCS data path is shown in Figure 3-1. It is assumed ASN#1 and ASN #2 are different MBS Zone.

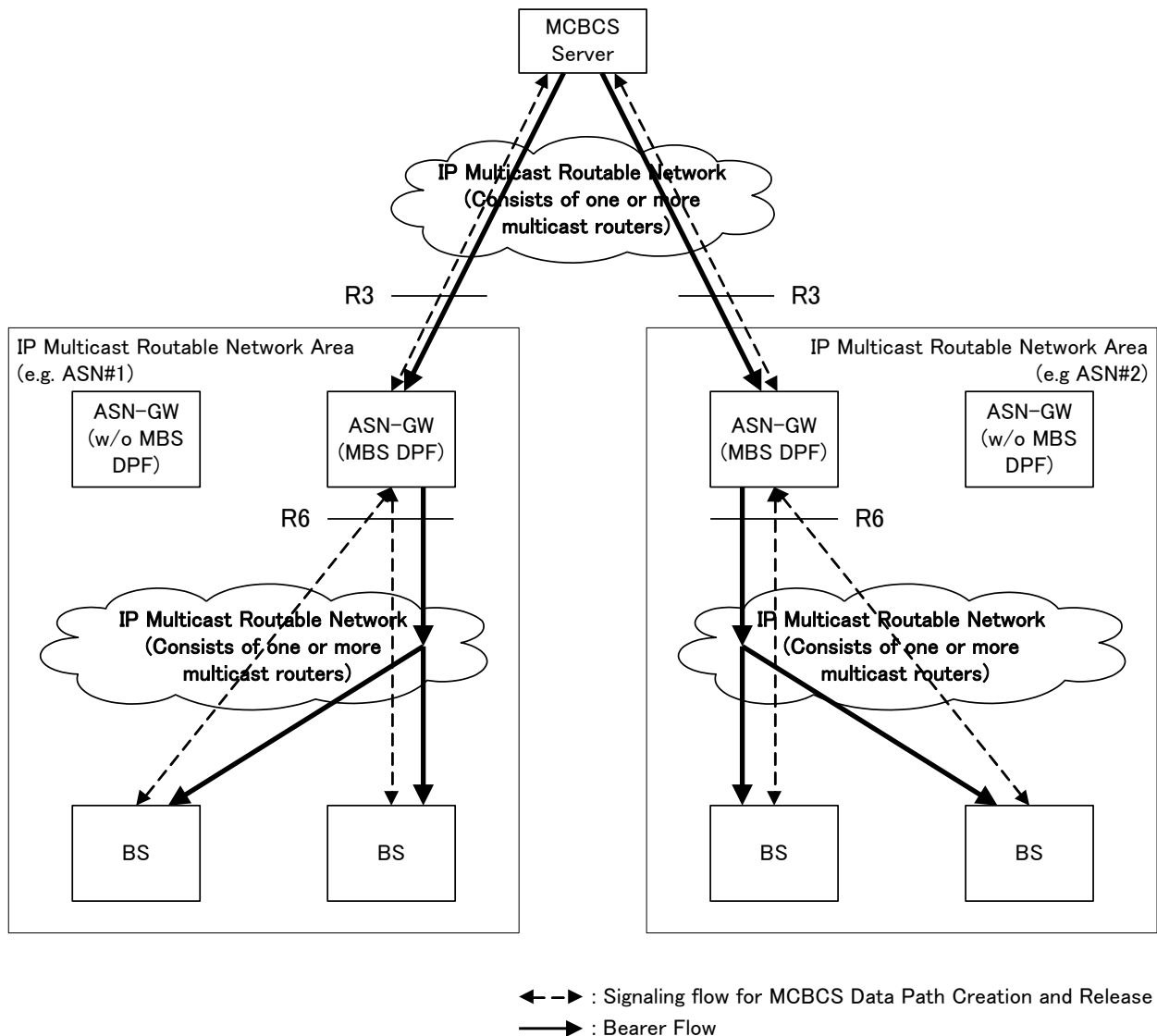

Figure 3-1 - Overview of MCBCS Data Path

MCBCS-Applayer

1 R3 MCBCS data path is created between MCBCS Server and ASN-GW having MBS DPF function and R3 packets
 2 are forwarded to the MBS DPF using IP multicast. R6 MCBCS data path is created between the MBS DPF and
 3 BS(s) within a MBS Zone, and R6 packets are forwarded from the MBS DPF to BS(s) using IP multicast.

4 MBS Zone SHALL consists of IP multicast routable network, then the R6 packets from MBS DPF can directly
 5 reach all BSs within the MBS Zone using IP multicast. If there are some BSs, which need to receive MBS content
 6 but IP multicast packets can't reach directly from a given MBS DPF (e.g. due to geographical restriction or network
 7 configuration restriction, etc.), those BSs SHALL belong to another MBS Zone and the MBS Zone SHALL be
 8 managed by another MBS Proxy/MBS DPF.

9
 10 For call flow of data path creation and release, see 4.2.5.1 and 4.2.6.1 respectively.

11

12 **3.2 Protocol Stack**

13 Figure 3-2 shows protocol stack for Type-4 MCBCS Data Plane.

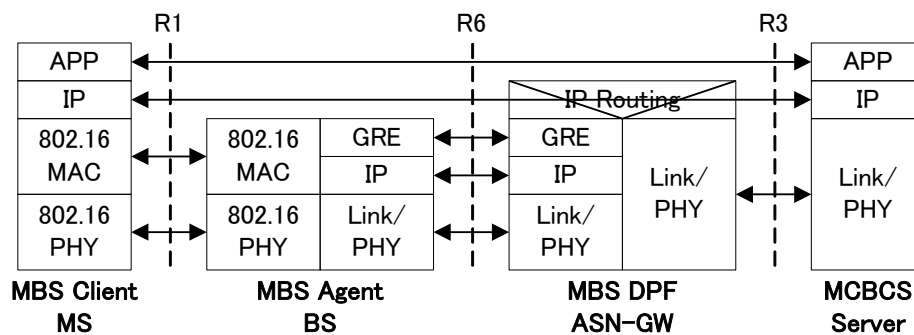

14

15 **Figure 3-2 - Protocol Stack for Type-4 MCBCS Data Plane**

16

17 **3.3 Transport on R3**

18 MCBCS Server sends the content packet based on the delivery rate of the content. MCBCS Server may encrypt the
 19 content before delivery. The content packet is transferred from MCBCS Server to the MBS DPF and the
 20 encapsulation (e.g. IP-in-IP, GRE, etc.) is not applied for the IP packet on R3. The destination IP address of the R3
 21 bearer packet is a multicast IP address assigned to the content, therefore the packet is transferred using IP multicast
 22 routing on R3. The mapping between the multicast IP address and the content is one-to-one.

23 In order to enable to receive the R3 bearer packet using IP multicast, the MBS DPF sends IGMP join [7][8] for IPv4,
 24 or MLD report for IPv6 [12][13], to the multicast router between ASN and CSN during R3 data path setup
 25 procedure.

26 MCBCS server should start transmitting the content after MCBCS data path setup completion and contents
 27 transmission time comes. However, for example, if the retransmission of R6 MCBCS data path creation message
 28 occurs, the contents transmission time may come before MCBCS data path creation completion. Also in this case,
 29 MCBCS server may start transmitting the content. In this situation, the MBS DPF may store the received packets or
 30 discard the packets until R6 data path creation completion or transfer the packets to BSs having already created R6
 31 MCBCS data path. Since it is implementation dependent, which procedure will be applied in the MBS DPF is
 32 outside the scope of this document.

33

1 **3.4 Transport on R6**

2 The MBS DPF identifies the contents by the multicast IP address of the received R3 packet and fragments/packs the
 3 packets based on the MBS subframe size. After that, the fragmented/packed packet is encapsulated by GRE header
 4 and transferred to BSs on R6.

5
 6

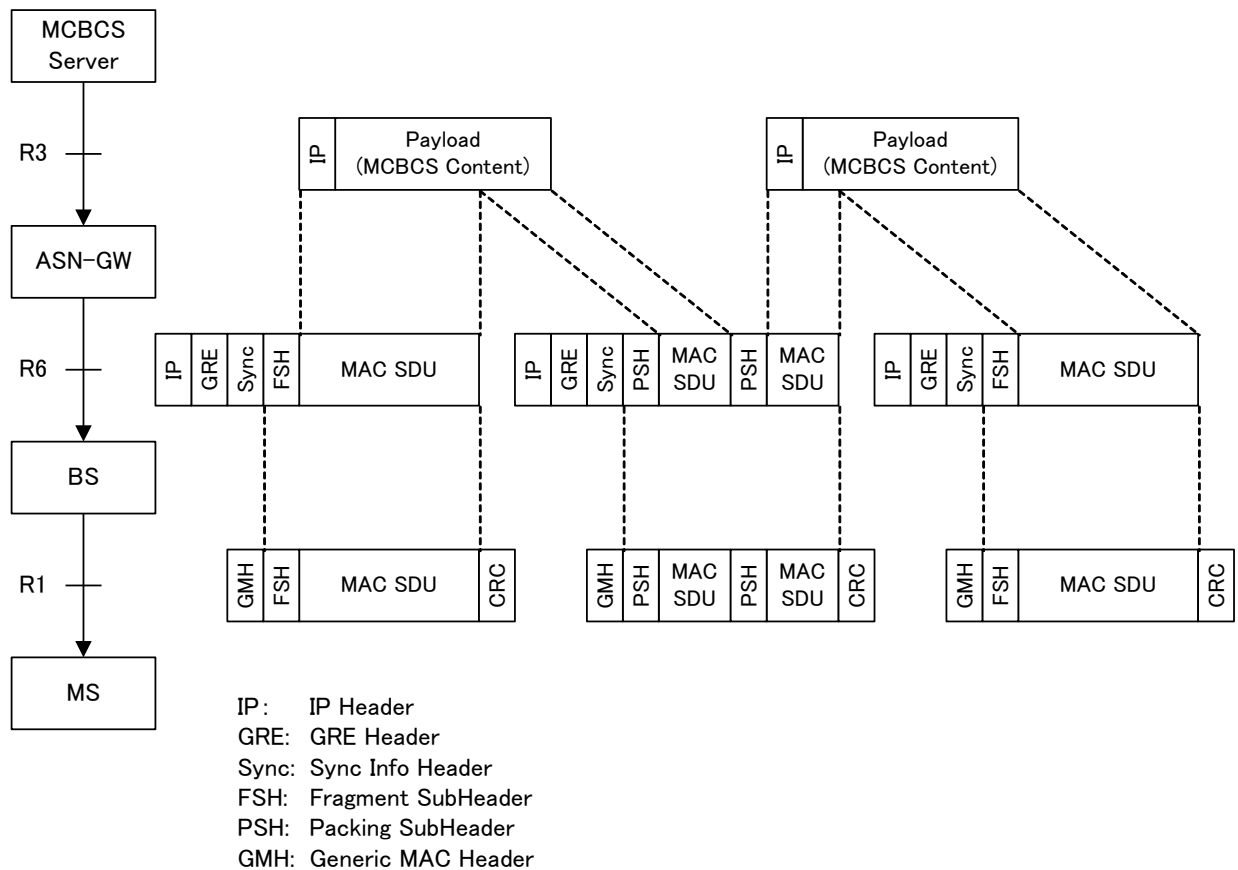

7
 8
 9

Figure 3-3 - Type-4 MCBCS Data Transfer

10 **3.4.1 Packetization**

11 MBS DPF shall fragment and pack the received R3 packet based on MBS burst size. The MBS burst size for the
 12 content is pre-configured by NAP. Fragment subheader and packing subheader, defined in IEEE 802.16, are
 13 generated to each fragmented/packed packet by MBS DPF in ASN-GW.

14

15 **3.4.2 GRE Encapsulation**

16 After the packetization, the MBS DPF shall encapsulate the packet with sync info header and GRE header. Sync
 17 info header is used to support the macro diversity with multi-BS.

18 Sync info header format is shown in Figure 3-4.

19

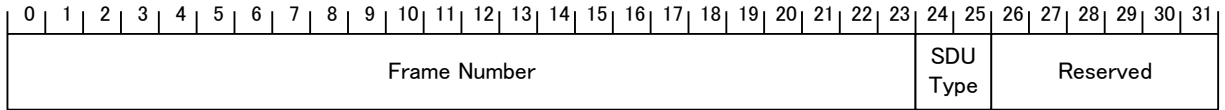

Figure 3-4 - Sync Info Header Format

Sync Info Header is 4 byte length and consists of 3 fields. Table 3-1 shows the description of each field.

Table 3-1 - Sync Info Header Field Definition

Field	Length	Type	Description
Frame Number	24 bits	Unsigned 24bits value	The frame number, which shall be synchronized by ASN_GW and BS, when BS should send the received packet from ASN-GW on the air frame.
SDU Type	2 bits	Unsigned 2bits value	This indicates the type of following payload. 00 : Neither fragmented nor packed (i.e. no FSH/PSH) 01 : Fragmented (i.e. with FSH) 10 : Packed (i.e. with PSH) 11 : Reserved
Reserved	6 bit	-	0

The Rule for creating Frame Number of sync header in ASN-GW and BS from ToD (Time of Day) of GPS: 64bit ToD (in 1.25ms units) is shifted 2bits to the right (i.e., divided by 4) and then, 24bit LSB is copied to FN.

- The base date of ToD: 0hour, 0min, 0sec, Jan. 6, 1980
- ToD accounting unit: 1.25ms, FN accounting unit: 5ms

MBS Proxy/MBS DPF calculates a frame number at which the packet shall be transferred on the air frame, using contents delivery start time received from MCBCS Server via *R3_Session_Start_Req* message in data path creation procedure and a transmission cycle of MBS data burst for the content which NAP may configure previously. MBS DPF sets Frame Number field of Sync Info header to the calculated frame number. Since detail formula of the frame number calculation is implementation dependent, it's outside the scope of this document.

The information of SDU Type is used to create GMH (Generic MAC Header) in BS.

GRE is specified by RFC 2784[9] and extended by 2890[10]. The GRE header shall be used without the checksum option. Therefore, the checksum present bit is set to zero. RFC 2890 provides two optional extensions, Key option and Sequence number option. Key option shall be used to identify the content on the R6. Key field consists of MBS Zone ID and MCID. The use of Sequence number option is optional.

GRE header format is shown in Figure 3-5. Description of each field is shown in Table 3-2.

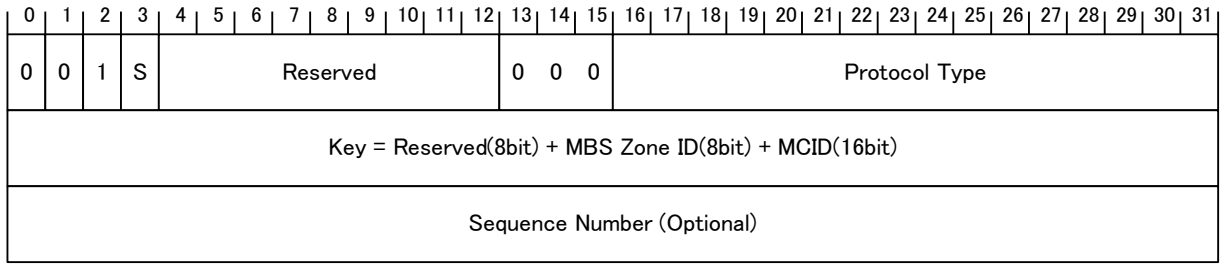

1

2

3

4

Figure 3-5 - GRE Header Format

Table 3-2 - GRE Header Field Definition

Field	Length	Type	Description
S	1 bit	-	This is Sequence Number Present bit. If the Sequence Number Present bit is set to 1, the Sequence Number field is present. Otherwise, the Sequence Number field is not present in the GRE header.
Protocol Type	16 bits	Unsigned 2bits value	This defines protocol type of the payload. It shall be “0xFFFF (WiMAX Payload Type)”.
Key	Reserved	8 bits	- 0
	MBS Zone ID	8 bits	Unsigned 8 bits value This identifies MBS Zone ID in which content is delivered. The range of this value is 1 ~ 127, where MSB is the reserved bit with being set to 0. If a subcell does not support MBS, then the MBS Zone ID of the subcell is set to 0.
	MCID	16 bits	Unsigned 16 bits value This identifies multicast connection ID which is assigned to the content. The range of this value for MBS is 0xFEAA0~0xFEFE, thus 95 MCIDs can be used for MBS.
Sequence Number (Optional)	32 bits	Unsigned 32 bits value	Optional value for enumeration sequence of the payload. If the Sequence Number is present in the GRE header, the S bit shall be set to 1.

5

3.4.3 IP Routing

The destination IP address of the R6 bearer packet is a multicast IP address assigned by ASN-GW or NAP per MBS Zone. Therefore, IP multicast routing is used for transport on R6.

In order to enable to receive the R6 packet using IP multicast, BS sends IGMP join for IPv4 or MLD report for IPv6, to the multicast router between BS and ASN-GW during R6 data path setup procedure. BS distinguishes the content for each MBS Zone using the key field in the GRE header.

12

1 **3.5 Transport on R1**

2 NAP previously configures all parameters of MBS_MAP_IE, MBS_MAP and MBS region (MBS permutation zone)
3 such as DIUC, repetition coding indication, permutation, boosting, Permbase_ID, PRBS_ID, Next MBS frame
4 offset, and the size and location of MBS_MAP and each MBS burst in DL subframe.

5 BS adds Generic MAC Header and CRC to the received packet from ASN-GW after decapsulating R6 GRE packet.

6 BS constructs MBS_MAP_IE and MBS_MAP, and maps the packet to MBS burst based on the frame number
7 specified by the sync info header.

8 MS acquires the MBS Zone ID and MCID mapped to the desirable contents from the mapping table acquired during

9 Service Announcement/Service Guide Delivery procedure (see 4.2.1.2) or during Subscription procedure

10 (see4.2.2.1). And MS receives the MBS burst based on the acquired MBS Zone ID and MCID.

4. Functional Design and Decomposition

4.1 High Level Control Flow Information

This section captures all control flows for the usage scenarios that are planned to be supported by NWG Rel-1.5 MCBCS. However, not all levels of these control flows (e.g. some at the application layer, and some at the network layer) will be within the scope of the NWG standardization – i.e. some may be for the information purpose only and some will become the normative descriptions.

Figure 4-1 shows a brief control flow on both MS side and NW side.

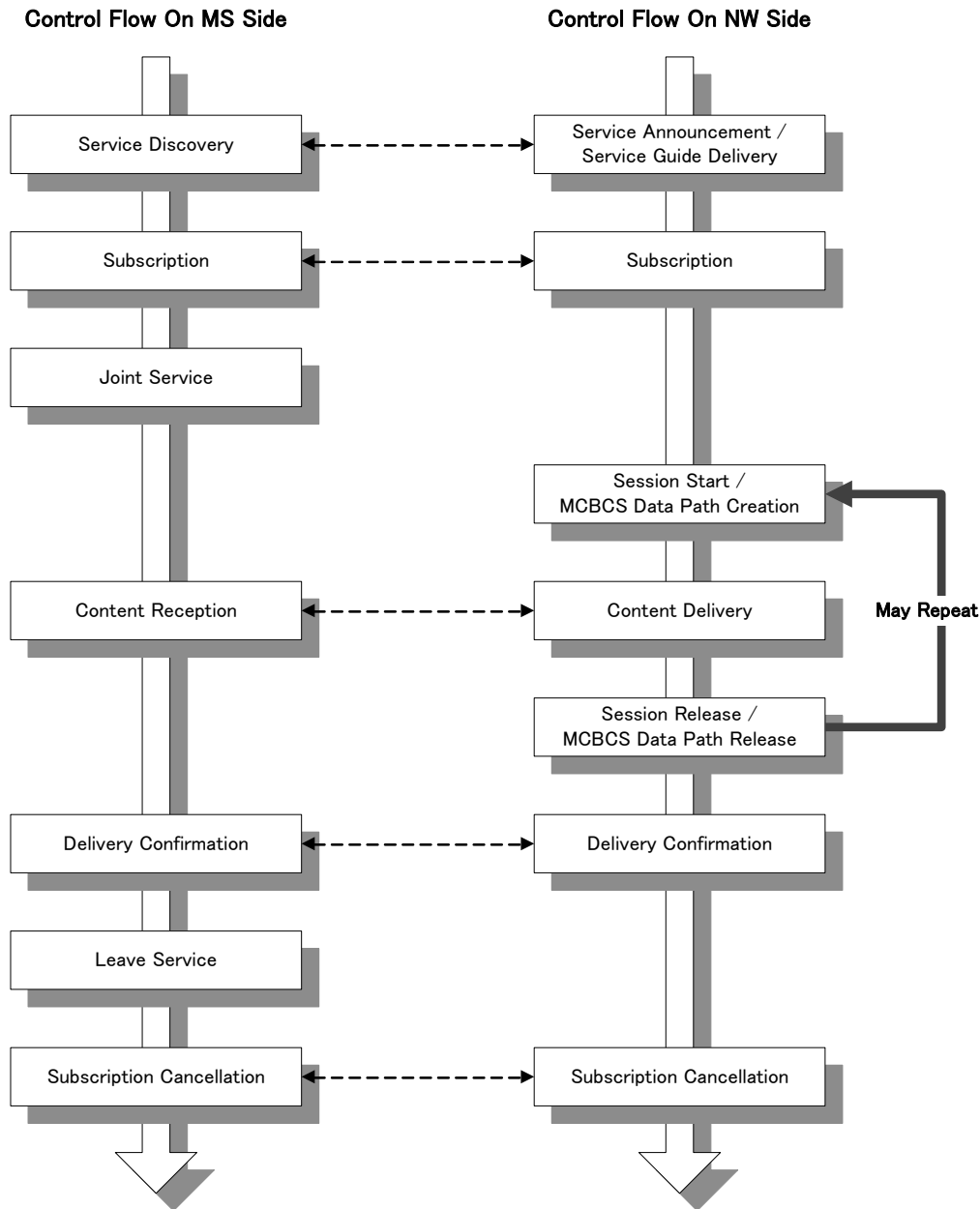

Figure 4-1 - Control Flow

(1) Service Announcement/Service Guide Delivery can be performed anytime during MCBCS service.

MCBCS-Applayer

- 1 (2) Subscription on NW side may be performed after Session Start because there may be some MSs joining the
- 2 service after content delivery starts.
- 3 (3) Session Start/Content Delivery/Session Release on Network side can be repeated.
- 4 (4) Delivery Confirmation process is optional.
- 5 (5) Subscription Cancellation may be performed anytime after Subscription.
- 6 For detail of each procedure in Figure 4-1, see chapter 4 and following sections.
- 7

1
2
3
4
5
6
7
8
9
10
11
12
13
14
15
16
17

4.2 Service Provisioning Procedures

4.2.1 MCBCS Service Discovery

4.2.1.1 Server Discovery

MS can find a MCBCS Server through a static or a dynamic method. In the static case, the IP address of MCBCS Server is provisioned in MS. In dynamic case, the several ways such as Broadcast can be used. In this document, only static method is considered.

4.2.1.2 Service Announcement/Service Guide Delivery

The Service Guide can be transmitted via Broadcast or Unicast manner. In this document, unicast manner is considered as default.

In Unicast manner, the MS sends a *Service Guide Request* message to the MCBCS Server in order to check what kinds of services are provided. On reception of the Service Guide Request message, the MCBCS Server responds to the MS with the Service Guide Response message which includes service related information such as the Program ID, Content ID, Schedule [Start and End time].

User Operation messages shall be coded using XML and transported via HTTP/TCP.

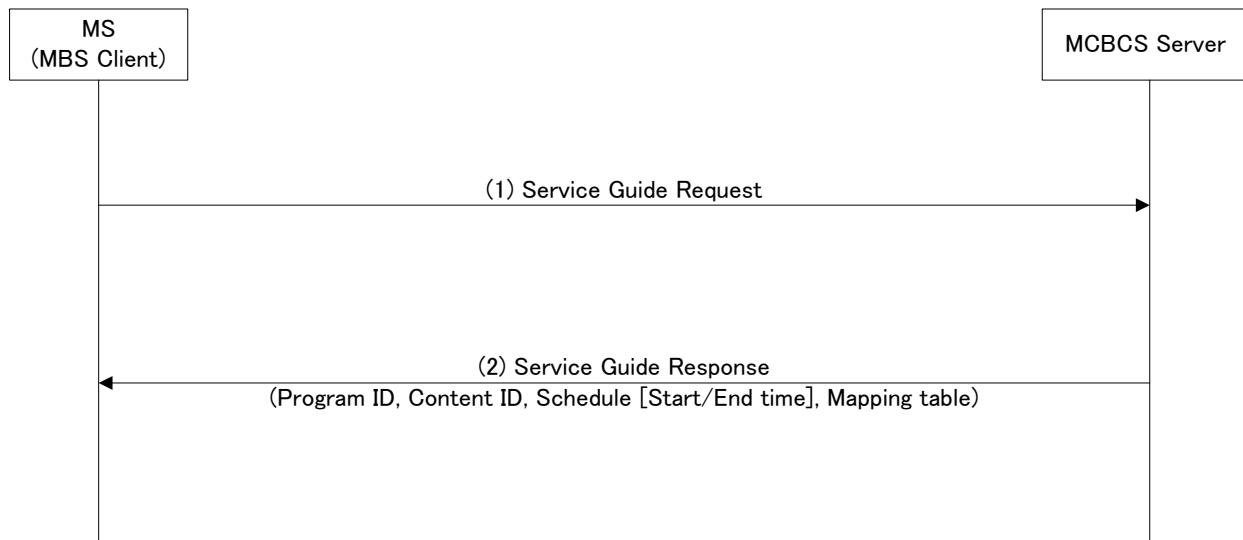

18
19
20
21
22
23
24
25
26

Figure 4-2 - Service Guide Acquisition

STEP 1

After the MS finds a MCBCS Server via a static or a dynamic MCBCS Server discovery method, the MS requests the Service Guide specifying what kinds of contents are provided by sending a *Service Guide Request* message to the MCBCS Server.

MCBCS-Applayer

1 **STEP 2**

2 Upon receipt of a *Service Guide Request* message, the MCBCS Server responds to the MS with a *Service Guide*
3 *Response* message which includes the Program ID, Content ID, Schedule [Start / End time] and etc.

4 Note: The general service guide includes the mapping table between the application layer ID (Program ID or
5 Content ID) and the IP layer ID (Contents IP) basically.

6 Note: Mapping table between Contents IP and MCID per MBS Zone ID can be delivered during either a Service
7 Guide acquisition or a Subscription procedure.

8 Note: The application client program of MS can obtain the mapping information for some specific MBS zones by
9 including the selected MBS zones within *Service Guide Request* message. The information of MBS zones can be
10 obtained reading the broadcasted MAC messages such as DCD or MBS_MAP_IE for MBS zone ID list in the
11 serving BS and MOB_NBR-ADV for MBS zone ID list in neighbor BS(s).

12

13 **4.2.1.3 Combined Message IEs**

14

Table 4-1 - Service Guide Request

IE	Reference	M/O	Notes
User Information		M	NAI (Username (NAI) during Step1 is not necessarily the NAI used for User/Device Authentication during WiMAX network access authentication.)

15

16

Table 4-2 - Service Guide Response

IE	Reference	M/O	Notes
Program Information		M	Include one or more Program ID.
> Program ID		M	
> Program Name		M	
>Program Description		M	e.g., Program Language
> CP Name		O	
> CP URL		O	
>MBS Zone Info		M	
>>MBS Zone ID		O	This is defined in IEEE 802.16e [2]. One MBS Zone consists of one or more BSs. MBS Zone ID = 0 shall not be used.
>> Macrodiversity-enabled		M	Indicate whether or not a MBS Zone is macrodiversity-enabled.

IE	Reference	M/O	Notes
>>Contents Info		M	Contains MBS contents information in the nested IEs.
>>>Contents ID		M	A Contents ID uniquely identifies MBS contents in MBS Server. One Contents ID is mapped to one R3 IP Multicast Address. It is the same as MBS Contents ID defined in IEEE 802.16e [2].
>>>MCID		O	It is defined in IEEE 802.16e [2] that an MCID is 12 bits over the R1 interface.
>>>Contents IP		M	Indicate the multicast IP address of content.
>>>UDP Port Number		M	
>>>Contents Type		M	Indicate the service type.
>>>Delivery Start Date		M	
>>>Delivery End Date		M	
>>>Delivery Start Time		M	Indicate MBS bust transfer start time at base station.
>>>Delivery End Time		M	Indicate MBS bust transfer end time at base station.
>>> Delivery Day of Week		M	Specified as follows: 1. Monday 2. Tuesday 3. Wednesday 4. Thursday 5. Friday 6. Saturday 7. Sunday

1

2

3 4.2.2 Subscription and Unsubscription

4 4.2.2.1 Subscription

5 If the user wants to receive the MCBCS service, he or she has to subscribe to the NSP. There are two kinds of
6 subscriptions. One is an online subscription, and the other is an offline subscription.

7 In online subscription, after the MS gets the Service Guide by Broadcast manner or Unicast manner, if he or she
8 would like to receive a MCBCS Service which the NSP provides, the user subscribes to the MCBCS Server which is
9 located in CSN. Upon reception of the subscription request, the MCBCS Server registers the user profile and
10 performs the user authentication and authorization with AAA. And, the AAA responds back to the MCBCS Server
11 with the authentication/authorization result.

1 Offline subscription is outside the scope of the standard.
2 Figure 4-3 describes the online subscription procedure.

3
4
5
6
7
8

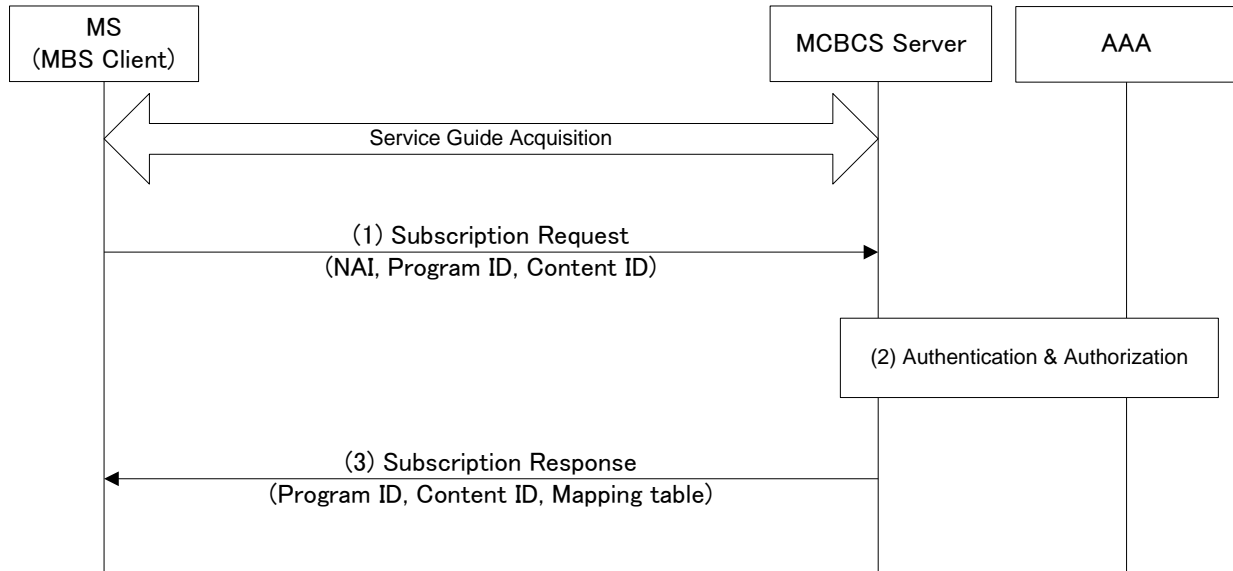

9

10 **Figure 4-3 - Online Subscription Procedure**

11

12 **STEP 1**

13 After receiving a Service Guide, the MS contacts the MCBCS Server for registering the Program(s) and the
14 content(s) to which user wants to subscribe. User information (NAI), Program ID and Content ID are included in
15 *Subscription Request* message.

16

17 **STEP 2**

18 The MCBCS Server sends user information to the AAA in order to let the MCBCS Server to perform an
19 authentication and an authorization.

20 AAA checks whether or not the requesting MS/User is authorized for service which MS/User describes and reports
21 the result back to the MCBCS Server.

22 If MS's subscription profile has been downloaded into MCBCS server, MCBCS server can authorize the MS
23 directly. But, if MCBCS server does not have the MS's subscription profile, it communicates with AAA. This
24 communication protocol is outside the scope of this document.

25

1 **STEP 3**

2 If the authentication and authorization are successful, the MCBCS Server responds to the MS with the *Subscription*
 3 *Response* message including a mapping table.

4 If the authentication and authorization fail, the MCBCS Server responds to the MS with Result=NG and appropriate
 5 NG Reason.

6
 7 Note: The mapping table between Multicast IP and MCID per MBS Zone ID is delivered during either a Service
 8 Guide acquisition or a Subscription procedure.

9 Note: The application client program of MS can obtain the mapping information for some specific MBS zones by
 10 including the selected MBS zones within *Subscription Request* message. The information of MBS zones can be
 11 obtained reading the broadcasted MAC messages such as DCD or MBS_MAP_IE for MBS zone ID list in the
 12 serving BS and NBR-ADV for MBS zone ID list in neighbor BS(s).

13

14

15 **4.2.2.2 Combined Message IEs**

16 **Table 4-3 - Subscription Request**

IE	Reference	M/O	Notes
User Information		M	NAI (Username (NAI) during Step1 is not necessarily the NAI used for User/Device Authentication during WiMAX network access authentication.)
Program Information		M	Include one or more Program ID.
> Program ID		M	
>Billing Method		O	

17

18

19 **Table 4-4 - Subscription Response**

IE	Reference	M/O	Notes
Results		M	
>Program ID		M	ID at Request is set.
>Result		M	OK/NG

IE	Reference	M/O	Notes
>NG Reason		O	This element shall contain the NG reason for Subscription. The NG reason is specified as follows: 1. Authorization has failed. 2. Requested program is not available. 3. Unknown Reason.
Program Information		O	This TLV shall be included, only for the program(s) which Result is OK
>Program ID		CM	This TLV shall be included if the Program Information is included.
>Program Name		O	
>Program Description		O	
>Program Size		CM	. This TLV shall be included if the Program Information is included.
>Contents Type		CM	Indicate the service type. This TLV shall be included if the Program Information is included.
>CP Name		O	
>CP URL		O	
>Unicast Retransmission URL		O	When multicast delivery fails, MS can download it from this URL. If this parameter doesn't exist, it is not possible to Unicast Retransmission.
>MBS Zone Info		CM	. This TLV shall be included if the Program Information is included.
>>MBS Zone ID		M	
>>Contents Info		M	.
>>>Contents ID		M	.

IE	Reference	M/O	Notes
>>>MCID		M	
>>>Contents IP		M	
>>>UDP Port Number		M	
>>>Contents Type		M	
>>>Encryption Key		O	
>>>Delivery Start Date		M	
>>>Delivery End Date		M	
>>>Delivery Start Time		M	
>>>Delivery End Time		M	
>>>Delivery Day of Week		M	specified as follows: 1. Monday 2. Tuesday 3. Wednesday 4. Thursday 5. Friday 6. Saturday 7. Sunday
>>Send Delivery Confirmation		M	0. Not necessary to transmit. 1. Necessary to transmit.

IE	Reference	M/O	Notes
Next Access Schedule		O	<p>The MS shall send Delivery Confirmation Notification at this date and time.</p> <p>(It will send it again by the unicast though it differs according to contents when the reception is NG when MS receives contents by the multicast.</p> <p>It is thought that the possibility that the network and MCBCS Server crowd is very high because traffic is explosively generated if MS demands the unicast sending again from MCBCS Server all together immediately after the multicast.</p> <p>Therefore, time when the unicast retransmission is done is specified for each MS to level the traffic explosively generated, and MS makes it access MCBCS Server at the specified time.</p> <p>The time that comes for the access from MS to MCBCS Server including this unicast retransmission is assumed to be Next Access Schedule.)</p>

1

2

1
2
3
4
5
6
7
8
9
10
11
12
13
14
15
16
17
18
19
20
21
22
23
24
25

4.2.2.3 Unsubscription

The user should notify NSP if the user wants to unsubscribe the MCBCS service.

Figure 4-4 describes the online unsubscription procedure.

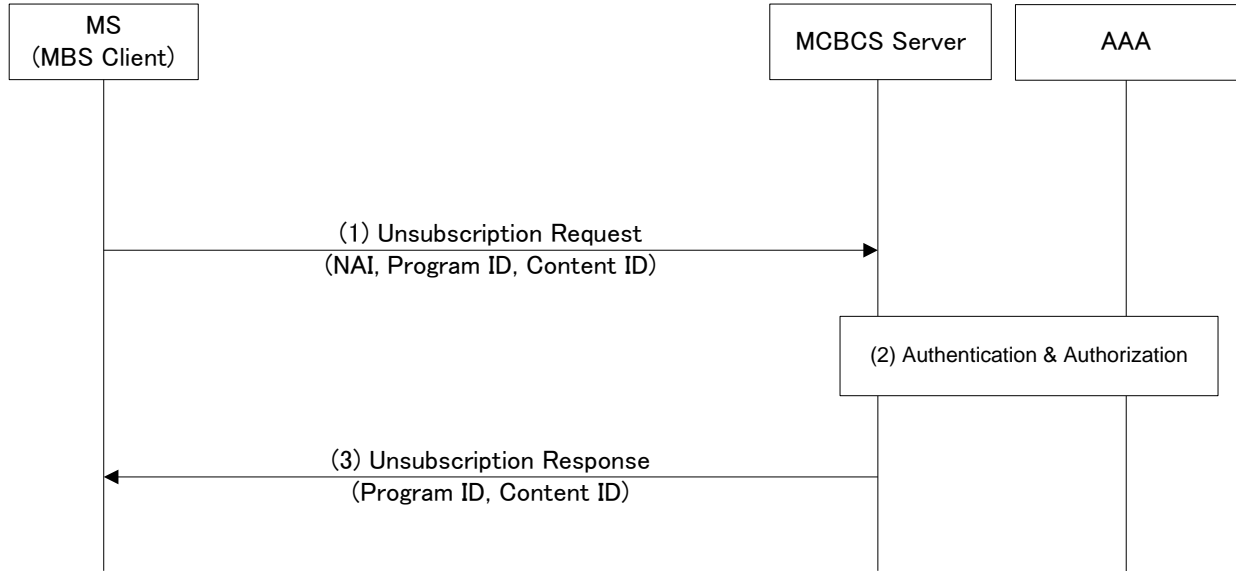

Figure 4-4 - Online Unsubscription Procedure

STEP 1

User information (NAI), Program ID are included in Unsubscription Request message.

STEP 2

The MCBCS Server sends user information to the AAA in order to let the MCBCS Server to perform an authentication and an authorization.

AAA checks whether or not the requesting MS/User is valid on service which MS/User describes and reports the result back to the MCBCS Server.

If MS's subscription profile has been downloaded into MCBCS server, MCBCS server can authorize the MS directly. But, if MCBCS server does not have the MS's subscription profile, it communicates with AAA. This communication protocol is out of scope in this document.

STEP 3

If the authentication and authorization are successful, the MCBCS Server responds to the MS with the Unsubscription Response message.

If the authentication and authorization fail, the MCBCS Server responds to the MS with Result=NG and appropriate NG Reason.

1 **4.2.2.4 Combined Message IEs**

2 **Table 4-5 - Unsubscription Request**

IE	Reference	M/O	Notes
User Information		M	NAI (Username (NAI) during Step1 is not necessarily the NAI used for User/Device Authentication during WiMAX network access authentication.)
Program Information		M	Include one or more Program ID.
> Program ID		M	

3

4 **Table 4-6 - Unsubscription Response**

IE	Reference	M/O	Notes
Results		M	
>Program ID		M	ID at Request is set.
>Result		M	OK/NG
>NG Reason		O	This element shall contain the NG reason for Unsubscription. The NG reason is specified as follows: 1. Authorization has failed. 2. Requested program is not available. 3. Unknown Reason.

5

6

7

1

2 **4.2.3 Service Announcement**

3 Refer to section 4.2.1.2.

4

5 **4.2.4 Joining Service**

6 After the Service Guide acquisition and the subscription procedure, the MS decides which MBS contents to watch.
 7 In broadcast and static multicast, the MS can receive the MBS contents which he or she wishes to watch without
 8 IGMP Join for IPv4 / MDL report for IPv6 procedure via selective decoding at MAC layer, where the selective
 9 decoding at MAC layer is possible since the MS already has a mapping table from the Service Guide Response or
 10 Subscription Response for the Content ID, Contents IP Address and the MCID. Figure 4-5 shows the basic MS
 11 internal operation for MBS content reception.

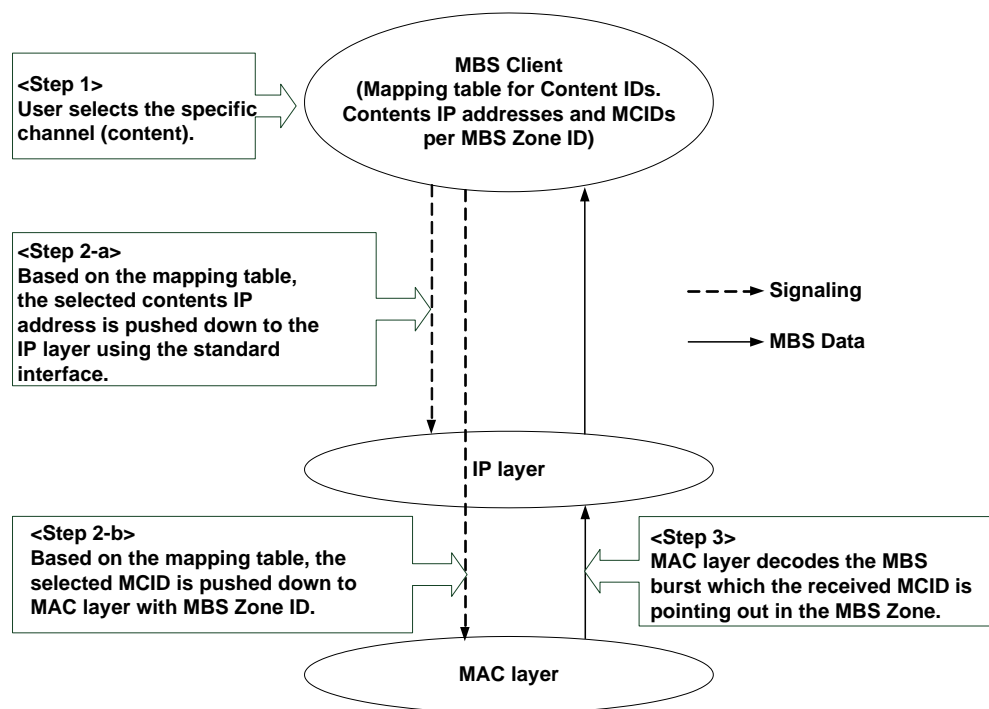

12

13

Figure 4-5 - MS Internal Operation

14 After a Service Guide acquisition and a Subscription procedure, the MS can perform channel change and inter-MBS
 15 zone mobility without any interactive signaling between BS and MS even in the idle or sleep mode. The MS enters
 16 and stays at the idle mode regardless of a channel change and inter-MBS Zone mobility.

17

18 When the User wants to watch a specific channel after MBS Client receives a Service Guide from MCBCS Server,
 19 he selects the specific channel. Then, the MBS Client pushes the Multicast IP address corresponding to the selected
 20 channel down to the IP layer and the MCID and MBS zone ID corresponding to the selected channel down to the
 21 MAC layer using the channel mapping information between layers among the Content ID(s), Multicast IP
 22 Address(es) and MCID(s). Based on the obtained MCID and MBS zone ID, MS can choose to only decode the
 23 MBS burst corresponding to the selected channel.

4.2.5 Session Start

A Session Start initiated from MCBCS Server is used for allocating the network resource efficiently. Although the network resource can be reserved any time, it's more efficient to allocate the resource of BS and ASN-GW at the point of an actual data transmission.

During a Session start, the service related information such as Content ID, MCID, Contents IP address, Schedule[Start/End time], MBS Zone ID and etc are transferred.

When the MBS Proxy receives the *Session_Start_Req* from the MCBCS Server, MBS DPF sends an IGMP Join for IPv4 / MLD report for IPv6 to MR to make the multicast connection.

4.2.5.1 MCBCS Data Path Creation

Figure 4-6 describes the MCBCS Data Path Creation procedure for the pre-scheduled MCBCS.

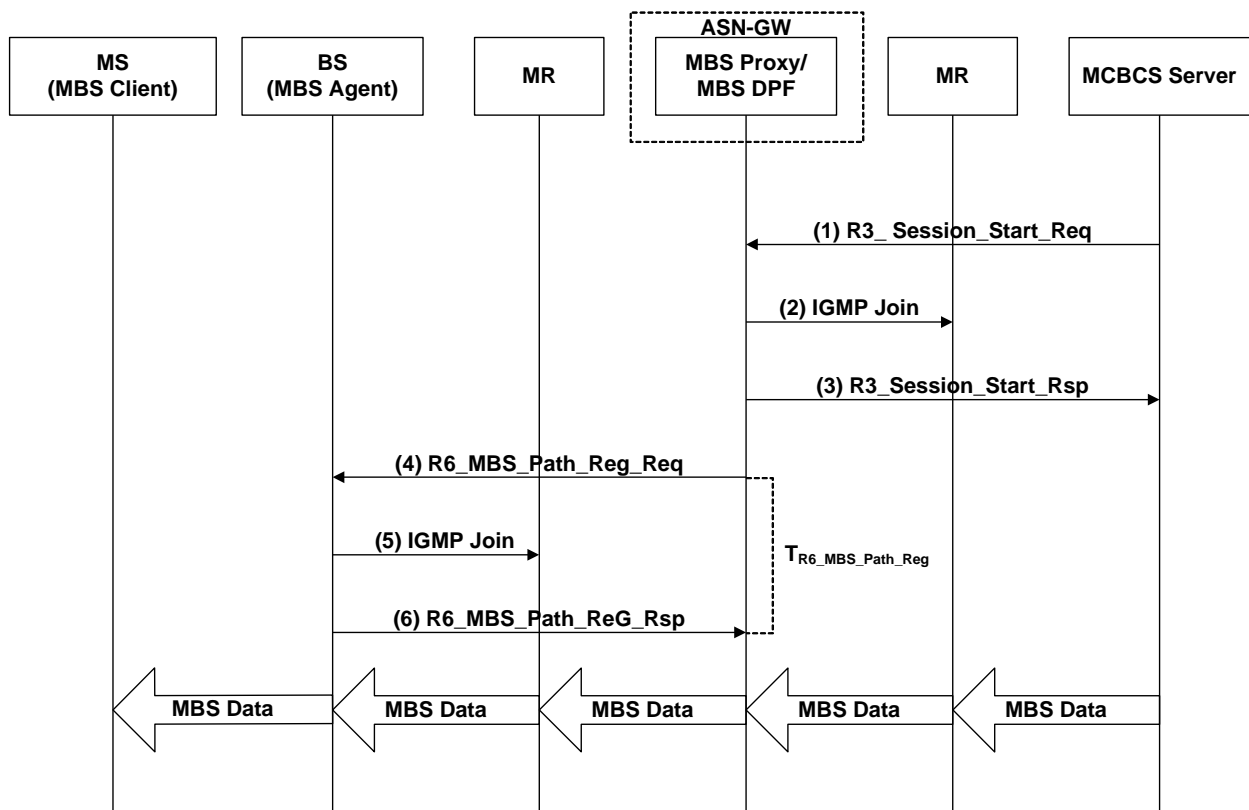

Figure 4-6 - MCBCS Data Path Creation Procedure

STEP 1

In advance of MBS data delivery, the MCBCS Server sends a *R3_Session_Start_Req* message to the MBS Proxy in order to request a multicast connection setup.

STEP 2

Upon receipt of the *R3_Session_Start_Req* message, MBS DPF sends an IGMP Join message for IPv4, or a MLD report message for IPv6, to the multicast router to establish the multicast connection based on Contents IP address included in STEP 1.

1
2
3
4
5
6
7
8
9
10
11
12
13
14
15
16
17
18
19
20
21
22

STEP 3

After establishing the multicast connection with the MCBCS Server, the MBS Proxy responds to the MCBCS Server with a *R3_Session_Start_Rsp* message.

STEP 4

The MBS DPF transmits a *R6_MBS_Path_Reg_Req* message to the BS to request a R6 data path establishment and a reservation of an air resource at the BS, and starts $T_{R6_MBS_Path_Reg}$ timer.

STEP 5

Upon receipt of the *R6_MBS_Path_Reg_Req* message, the BS sends an IGMP Join message for IPv4, or a MLD report message for IPv6, to the multicast router to establish the multicast connection based on information received from STEP 4.

STEP 6

After the multicast connection setup, the BS sends a *R6_MBS_Path_Reg_Rsp* message to the MBS DPF as a response of the *R6_MBS_Path_Reg_Req* message. Upon reception of *R6_MBS_Path_Reg_Rsp* message, the MBS DPF stops $T_{R6_MBS_Path_Reg}$ timer.

4.2.5.2 Combined Message IEs

Table 4-7 - R6_MBS_Path_Reg_Req

IE	Reference	M/O	Notes
MBS Zone Info	6.2.2.9	M	Contains MBS Zone-related content information in the nested IEs.
> MBS Zone ID	6.2.2.8	M	This is defined in IEEE 802.16e [2]. One MBS Zone consists of one or more BSs. MBS Zone ID = 0 shall not be used.
>R6 Multicast IP	6.2.2.11	M	Multicast IP address for establishing multicast connection between the ASN-GW and the BS
>Contents Info	6.2.2.2	M	Contains MBS contents information in the nested IEs.
>>Contents ID	6.2.2.1	M	A Contents ID uniquely identifies MBS contents in MBS Server. One Contents ID is mapped to one R3 IP Multicast Address. It is the same as MBS Contents ID defined in IEEE 802.16e [2].
>>Contents Type	6.2.2.4	M	Indicate the service type.

IE	Reference	M/O	Notes
>>GRE KEY	6.2.2.7	O	After packetization, the fragmented/packed packet is encapsulated by GRE header and transferred to BSs on R6. GRE KEY field in GRE header consists of MBS Zone ID and MCID. The Key shall be used to identify the content on the R6.
>>MCID	6.2.2.10	M	It is defined in IEEE 802.16e [2] that an MCID is 12 bits over the R1 interface.
>>Delivery Start Time	6.2.2.6	M	Indicate MBS bust transfer start time at base station.
>>Delivery End Time	6.2.2.5	M	Indicate MBS bust transfer end time at base station.
> Macrodiversity-enabled	6.2.2.13	O	Indicate whether or not a MBS Zone is macrodiversity-enabled

1

2 Note: MBD DPF ID and BS ID are used as Source/Destination Identifier

3

1
2

Table 4-8 - R6_MBS_Path_Reg_Rsp

IE	Reference	M/O	Notes
Failure Indication	5.3.2.69 [Ref.5]	O	Indicate the reason of failure.
MBS Zone Info	6.2.2.9	M	Contains MBS Zone-related content information in the nested IEs.
> MBS Zone ID	6.2.2.8	M	This is defined in IEEE 802.16e [2]. One MBS Zone consists of one or more BSs. MBS Zone ID = 0 shall not be used.
>Contents Info	6.2.2.2	M	Contains MBS contents information in the nested IEs.
>>Contents ID	6.2.2.1	M	A Contents ID uniquely identifies MBS contents in MBS Server. One Contents ID is mapped to one R3 IP Multicast Address. It is the same as MBS Contents ID defined in IEEE 802.16e [2].
>>MCID	6.2.2.10	M	It is defined in IEEE 802.16e [2] that an MCID is 12 bits over the R1 interface.
>> MCID Reservation Result	6.2.2.14	M	Indicate the MCID reservation result

3 Note: MBD DPF ID and BS ID are used as Source/Destination Identifier.

4
5

Table 4-9 - R3_Session_Start_Req

IE	Reference	M/O	Notes
MBS Zone Info	6.2.2.9	M	Contains MBS Zone-related content information in the nested IEs.
> MBS Zone ID	6.2.2.8	M	This is defined in IEEE 802.16e [2]. One MBS Zone consists of one or more BSs. MBS Zone ID = 0 shall not be used.
>Contents Info	6.2.2.2	M	Contains MBS contents information in the nested IEs.
>>Contents ID	6.2.2.1	M	A Contents ID uniquely identifies MBS contents in MBS Server. One Contents ID is mapped to one R3 IP Multicast Address. It is the same as MBS Contents ID defined in IEEE 802.16e [2].
>>MCID	6.2.2.10	M	It is defined in IEEE 802.16e [2] that an MCID is 12 bits over the R1 interface.

IE	Reference	M/O	Notes
>>Contents IP	6.2.2.3	M	R3 Multicast IP address for Contents
>>Contents Type	6.2.2.4	M	Indicate the service type.
>>Delivery Start Time	6.2.2.6	M	Indicate MBS bust transfer start time at base station.
>>Delivery End Time	6.2.2.5	M	Indicate MBS bust transfer end time at base station.

1

2

1
 2

Table 4-10 - R3_Session_Start_Rsp

IE	Reference	M/O	Notes
Failure Indication	5.3.2.69 [Ref.5]	O	Indicate the reason of failure.
MBS Zone Info	6.2.2.9	M	Contains MBS Zone-related content information in the nested IEs.
> MBS Zone ID	6.2.2.8	M	This is defined in IEEE 802.16e [2]. One MBS Zone consists of one or more BSs. MBS Zone ID = 0 shall not be used.
>Contents Info	6.2.2.2	M	Contains MBS contents information in the nested IEs.
>>Contents ID	6.2.2.1	M	A Contents ID uniquely identifies MBS contents in MBS Server. One Contents ID is mapped to one R3 IP Multicast Address. It is the same as MBS Contents ID defined in IEEE 802.16e [2].
>>MCID	6.2.2.10	M	It is defined in IEEE 802.16e [2] that an MCID is 12 bits over the R1 interface.
>> MCID Reservation Result	6.2.2.14	M	Indicate the MCID reservation result

3
 4

1

2 **4.2.5.3 Error Handling During MCBCS Data Path Creation**

3 **4.2.5.3.1 MCBCS Data Path Creation Failure under All BSs**

4 Figure 4-7 shows the call flow of the MCBCS data path creation failure under all BSs case.

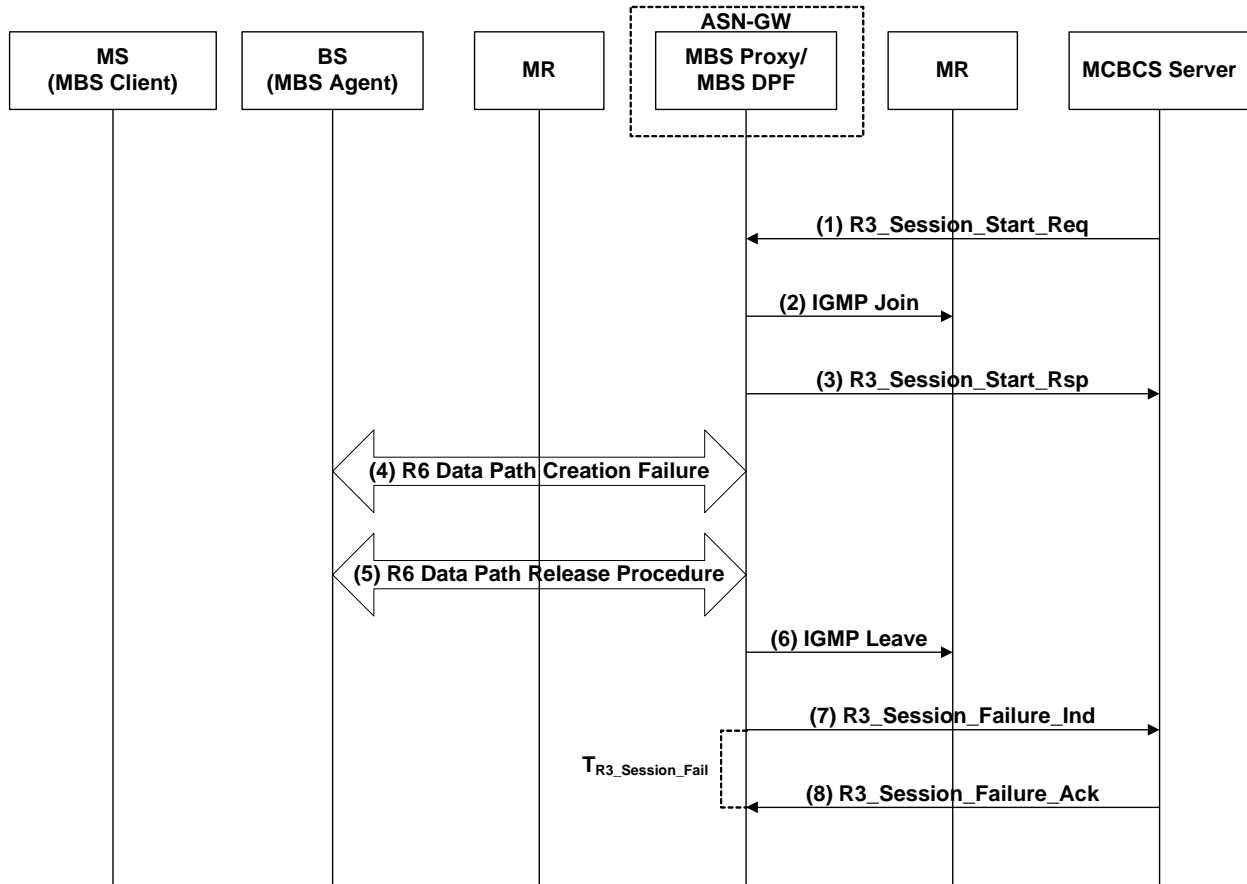

5

6 **Figure 4-7 - MCBCS Data Path Creation Failure under All BSs**

7

8 **STEP 1**

9 In advance of MBS data delivery, the MCBCS Server sends a *R3_Session_Start_Req* message to the MBS Proxy in
 10 order to request a multicast connection setup.

11

12 **STEP 2**

13 Upon receipt of the *R3_Session_Start_Req* message, MBS DPF sends an IGMP Join message for IPv4, or a MLD
 14 report message for IPv6, to the multicast router to establish the multicast connection based on Contents IP address
 15 included in STEP 1.

16

17 **STEP 3**

18 After establishing the multicast connection with the MCBCS Server, the MBS Proxy responds to the MCBCS
 19 Server with a *R3_Session_Start_Rsp* message.

MCBCS-Applayer

1

2 **STEP 4**

3 MBD DPF considers that R6 MCBCS data path creation is failed if it receives *R6_MBS_Path_Reg_Rsp* message
 4 including Failure Indication TLV, all of MCID Reservation Result set to "Failure" or $T_{R6_MBS_Path_Reg}$ expires after
 5 max retransmission of *R6_MBS_Path_Reg_Req* message.

6

7 **STEP 5**

8 If R6 MCBCS data path creation is failed due to $T_{R6_MBS_Path_Reg}$ expires after max retransmission of
 9 *R6_MBS_Path_Reg_Req* message in step5, the MBS DPF performs R6 MCBCS data path release procedure.

10

11 **STEP 6**

12 If MBS Proxy/MBS DPF decides that MCBCS data path creation is failed under all BSs with a MBS Zone, the MBS
 13 DPF sends an IGMP Leave message for IPv4, or a MLD done/report message for IPv6, to the multicast router to
 14 release the multicast connection.

15

16 **STEP 7**

17 MBS Proxy sends *R3_Session_Failure_Ind* message to MCBCS Server to inform it that data path creation is failed
 18 and starts $T_{R3_Session_Fail}$ timer. If MCBCS Server receives the *R3_Session_Failure_Ind* message, MCBCS Server
 19 should stop the content delivery.

20

21 **STEP 8**

22 Upon receipt of *R3_Session_Failure_Ind* message, MCBCS Server sends *R3_Session_Failure_Ack* message to the
 23 MBS Proxy. Upon receipt of *R3_Session_Failure_Ack* message, the MBS Proxy stops $T_{R3_Session_Fail}$ timer.

24

25 **4.2.5.3.2 Combined Message IEs**

26

27

Table 4-11 - R3 Session_Failure_Ind

IE	Reference	M/O	Notes
MBS Zone Info	6.2.2.9	M	Contains MBS Zone-related content information in the nested IEs.
>MBS Zone ID	6.2.2.8	M	This is defined in IEEE 802.16e [2]. One MBS Zone consists of one or more BSs. MBS Zone ID = 0 shall not be used.
>Contents Info	6.2.2.2	M	Contains MBS contents information in the nested IEs.
>>Contents ID	6.2.2.1	M	A Contents ID uniquely identifies MBS contents in MBS Server. One Contents ID is mapped to one R3 IP Multicast Address. It is the same as MBS Contents ID defined in IEEE 802.16e [2].
>>MCID	6.2.2.10	M	It is defined in IEEE 802.16e [2] that an MCID is 12 bits over the R1 interface.

1
2

Table 4-12 - R3_Session_Failure_Ack

IE	Reference	M/O	Notes
Failure Indication	5.3.2.69 [Ref.5]	O	Indicate the reason of failure.
MBS Zone Info	6.2.2.9	M	Contains MBS Zone-related content information in the nested IEs.
>MBS Zone ID	6.2.2.8	M	This is defined in IEEE 802.16e [2]. One MBS Zone consists of one or more BSs. MBS Zone ID = 0 shall not be used.
>Contents Info	6.2.2.2	M	Contains MBS contents information in the nested IEs.
>>Contents ID	6.2.2.1	M	A Contents ID uniquely identifies MBS contents in MBS Server. One Contents ID is mapped to one R3 IP Multicast Address. It is the same as MBS Contents ID defined in IEEE 802.16e [2].
>>MCID	6.2.2.10	M	It is defined in IEEE 802.16e [2] that an MCID is 12 bits over the R1 interface.

3
4

4.2.5.3.3 Timers and Timing Considerations

This section identifies the timer that the entities participating in the MCBCS Data Path Creation procedure SHALL use. MCBCS Data Path Creation procedure utilizes two timers:

8
9
10
11
12

1. $T_{R6_MBS_Path_Reg}$: is started by MBS DPF upon sending *R6_MBS_Path_Reg_Req*. It is stopped upon receiving a corresponding *R6_MBS_Path_Reg_Rsp*.
2. $T_{R3_Session_Fail}$: is started by MBS Proxy upon sending an *R3_Session_Failure_Ind*. It is stopped upon receiving a corresponding *R3_Session_Failure_Ack*.

13
14

Table 4-13 shows the default value of timers and also indicates the range of the recommended duration of these timers.

15

Table 4-13 - Timer Values for MCBCS Path Creation Procedure

Timer	Default Values (msec)	Criteria	Maximum Timer Value (msec)
$T_{R6_MBS_Path_Reg}$	1000	100ms	25500
$T_{R3_Session_Fail}$	1000	100ms	25500

16

4.2.5.3.4 Handling Error Conditions

17
18
19

Table 4-14 lists the behavior for various error conditions during MCBCS Data Path Creation:

1
 2

Table 4-14 - MCBCS Data Path Creation – Handling Error Conditions

	Failure Case	Action
1	A response message doesn't matching to a sent request/indication message (e.g. if MBS Zone ID or MCID or ContentsID or Transaction ID of a response message doesn't match to a sent request/indication message.).	<ul style="list-style-type: none"> The receiver SHALL silently discard the response message.
2	MBS DPF doesn't receive <i>R6_MBS_Path_Reg_Rsp</i> from BS.	<ul style="list-style-type: none"> MBS DPF SHALL retransmit <i>R6_MBS_Path_Reg_Req</i> with the same transaction ID until max of retransmission if $T_{R6_MBS_Path_Reg}$ is expired. If $T_{R6_MBS_Path_Reg}$ is expired after maximum number of retransmissions, MBS DPF performs R6 MCBCS data path release procedure. If R6 MBS Path creation is failed for all BSs, MBS Proxy sends <i>R3_Session_Failure_Ind</i> to MCBCS server to inform it of the path creation failure and releases R3 session.
3	MBS Proxy receives invalid <i>R3_Session_Start_Req</i> .	<ul style="list-style-type: none"> MBS Proxy SHALL send <i>R3_Session_Start_Rsp</i> with an appropriate failure indication value. MCBCS Server doesn't retransmit <i>R3_Session_Start_Req</i>.
4	BS receives invalid <i>R6_MBS_Path_Reg_Req</i> .	<ul style="list-style-type: none"> BS SHALL send <i>R6_MBS_Path_Reg_Rsp</i> with an appropriate failure indication value. MBS DPF doesn't retransmit <i>R6_MBS_Path_Reg_Req</i>. If R6 MBS Path creation is failed for all BSs, MBS Proxy sends <i>R3_Session_Failure_Ind</i> to MCBCS server to inform it of the path creation failure and releases R3 session.
5	MBS Proxy doesn't receive <i>R3_Session_Failure_Ack</i> from MCBCS Server.	<ul style="list-style-type: none"> MBS Proxy SHALL retransmit <i>R3_Session_Failure_Ind</i> until max of retransmission if $T_{R3_Session_Fail}$ is expired. If $T_{R3_Session_Fail}$ is expired after maximum number of retransmissions, MBS Proxy/MBS DPF releases R3 MCBCS data path.
6	MCBCS Server receives invalid <i>R3_Session_Failure_Ind</i> .	<ul style="list-style-type: none"> MCBCS Server SHALL send <i>R3_Session_Failure_Ack</i> with an appropriate failure indication value. MBS Proxy doesn't retransmit

	Failure Case	Action
		<i>R3_Session_Failure_Ind.</i>

1

2 **4.2.5.3.5 Timer Expiry**

3 Table 4-15 shows the details of corresponding actions upon timer expiration. Upon each timer expiry, if the number
 4 of retries has not exceeded the maximum, the timer is restarted. Otherwise, the corresponding action(s) should be
 5 performed as indicated in Table 4-15.

6

Table 4-15 - Timer Max Retry Conditions

Timer	Entity where Timer Started	Action(s)
T _{R6_MBS_Path_Reg}	ASN-GW (MBS DPF)	If this timer expires after max retry, MBS DPF releases the data path for the BSs.
T _{R3_Session_Fail}	ASN-GW (MBS Proxy)	If this timer expires after max retry, MBS Proxy/MBS DPF releases R3 MCBCS data path.

7

8

1

2 **4.2.6 Session Stop**

3 A Session Stop which is triggered by MCBCS Server is used for releasing the network resource of ASN-GW and
 4 BS(s). If there is no MBS contents which the MCBCS Server will transmit for a long time, the MCBCS Server will
 5 transmits the *Session_Rel_Req* message to the MBS Proxy. After the MBS Proxy receives the *Session_Rel_Req*
 6 message, it triggers the MBS Proxy/MBS DPF to get rid of the allotted network resource. And, the MBS DPF
 7 initiates the R6 data path release procedure.

8

9 **4.2.6.1 MCBCS Data Path Release**

10 Figure 4-8 describes the MCBCS Data Path Release procedure.

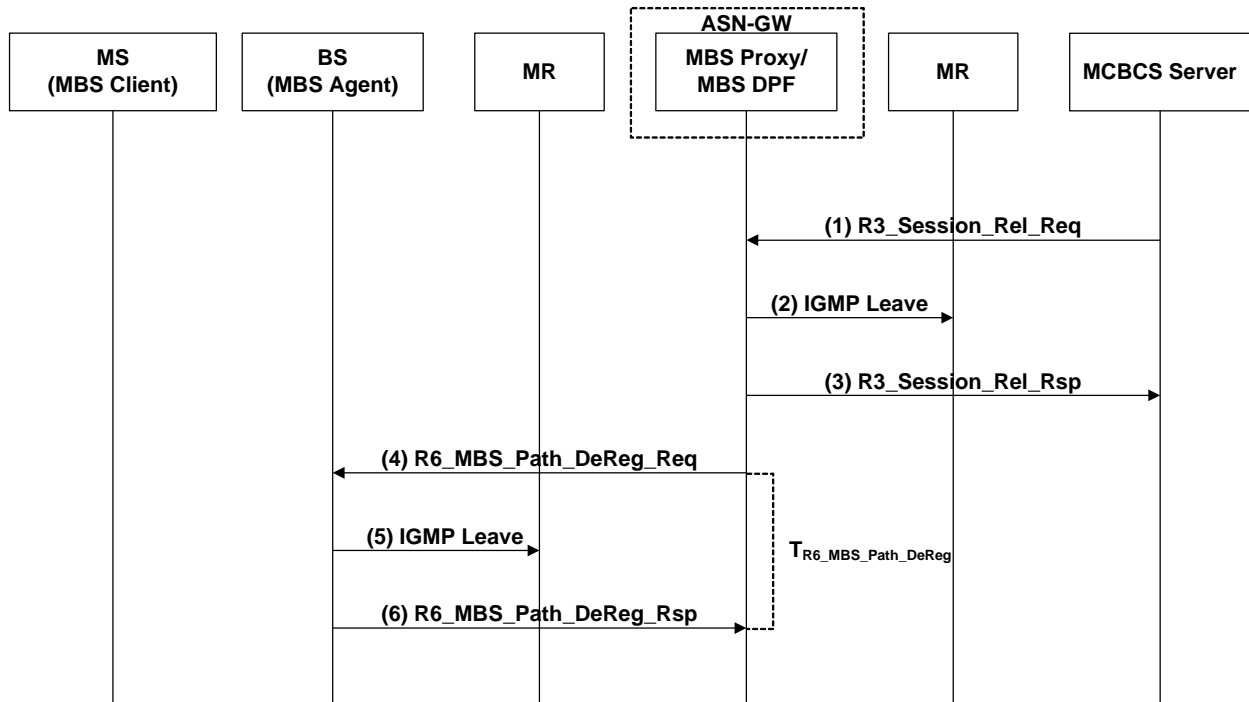

11

12 **Figure 4-8 - MCBCS Data Path Release Procedure**

13

14 **STEP 1**

15 When the MBS data delivery is completed, the MCBCS Server sends a *R3_Session_Rel_Req* message to the MBS
 16 Proxy in order to request a multicast connection release.

17

18 **STEP 2**

19 Upon receipt of the *R3_Session_Rel_Req* message, MBS DPF sends an IGMP Leave message for IPv4, or a MDL
 20 done/report message for IPv6, to the multicast router to release the multicast connection based on the information
 21 received in STEP 1.

22

23 **STEP 3**

24 After releasing the multicast connection with the MCBCS Server, the MBS Proxy responds to the MCBCS Server
 with a *R3_Session_Rel_Rsp* message.

1

2 **STEP 4**

3 The MBS DPF transmits a *R6_MBS_Path_DeReg_Req* message to the BS to request a R6 data path release and get
4 rid of an air resource at the BS, and starts $T_{R6_MBS_Path_DeReg}$ timer.

5

6 **STEP 5**

7 Upon receipt of the *R6_MBS_Path_DeReg_Req* message, the BS sends an IGMP Leave message for IPv4, or a
8 MDL done/report message for IPv6, to the multicast router to release the multicast connection based on information
9 received from STEP 4.

10

11 **STEP 6**

12 After the multicast connection release, the BS sends a *R6_MBS_Path_DeReg_Rsp* message to the MBS DPF as a
13 response of the *R6_MBS_Path_DeReg_Req* message. Upon reception of *R6_MBS_Path_DeReg_Rsp* message, the
14 MBS DPF stops $T_{R6_MBS_Path_DeReg}$ timer.

15

16 **4.2.6.2 Combined Message IEs**

17

Table 4-16 - R6_MBS_Path_DeReg_Req

IE	Reference	M/O	Notes
MBS Zone Info	6.2.2.9	M	Contains MBS Zone-related content information in the nested IEs.
> MBS Zone ID	6.2.2.8	M	This is defined in IEEE 802.16e [2]. One MBS Zone consists of one or more BSs. MBS Zone ID = 0 shall not be used.
>Contents Info	6.2.2.2	M	Contains MBS contents information in the nested IEs.
>>Contents ID	6.2.2.1	M	A Contents ID uniquely identifies MBS contents in MBS Server. One Contents ID is mapped to one R3 IP Multicast Address. It is the same as MBS Contents ID defined in IEEE 802.16e [2].
>>MCID	6.2.2.10	M	It is defined in IEEE 802.16e [2] that an MCID is 12 bits over the R1 interface.

18 Note: MBD DPF ID and BS ID are used as Source/Destination Identifier.

19

20

Table 4-17 - R6_MBS_Path_DeReg_Rsp

IE	Reference	M/O	Notes

IE	Reference	M/O	Notes
Failure Indication	5.3.2.69 [Ref.5]	O	Indicate the reason of failure.
MBS Zone Info	6.2.2.9	M	Contains MBS Zone-related content information in the nested IEs.
> MBS Zone ID	6.2.2.8	M	This is defined in IEEE 802.16e [2]. One MBS Zone consists of one or more BSs. MBS Zone ID = 0 shall not be used.
>Contents Info	6.2.2.2	M	Contains MBS contents information in the nested IEs.
>>Contents ID	6.2.2.1	M	A Contents ID uniquely identifies MBS contents in MBS Server. One Contents ID is mapped to one R3 IP Multicast Address. It is the same as MBS Contents ID defined in IEEE 802.16e [2].
>>MCID	6.2.2.10	M	It is defined in IEEE 802.16e [2] that an MCID is 12 bits over the R1 interface.
>> MCID Reservation Result	6.2.2.14	M	Indicate the MCID reservation result

1

2 Note: MBD DPF ID and BS ID are used as Source/Destination Identifier

3

4

5

Table 4-18 - R3_Session_Rel_Req

IE	Reference	M/O	Notes
MBS Zone Info	6.2.2.9	M	Contains MBS Zone-related content information in the nested IEs.
> MBS Zone ID	6.2.2.8	M	This is defined in IEEE 802.16e [2]. One MBS Zone consists of one or more BSs. MBS Zone ID = 0 shall not be used.
>Contents Info	6.2.2.2	M	Contains MBS contents information in the nested IEs.
>>Contents ID	6.2.2.1	M	A Contents ID uniquely identifies MBS contents in MBS Server. One Contents ID is mapped to one R3 IP Multicast Address. It is the same as MBS Contents ID defined in IEEE 802.16e [2].
>>MCID	6.2.2.10	M	It is defined in IEEE 802.16e [2] that an MCID is 12 bits over the R1 interface.

6

7

1

Table 4-19 - R3_Session_Rel_Rsp

IE	Reference	M/O	Notes
Failure Indication	5.3.2.69 [Ref.5]	O	Indicate the reason of failure.
MBS Zone Info	6.2.2.9	M	Contains MBS Zone-related content information in the nested IEs.
> MBS Zone ID	6.2.2.8	M	This is defined in IEEE 802.16e [2]. One MBS Zone consists of one or more BSs. MBS Zone ID = 0 shall not be used.
>Contents Info	6.2.2.2	M	Contains MBS contents information in the nested IEs.
>>Contents ID	6.2.2.1	M	A Contents ID uniquely identifies MBS contents in MBS Server. One Contents ID is mapped to one R3 IP Multicast Address. It is the same as MBS Contents ID defined in IEEE 802.16e [2].
>>MCID	6.2.2.10	M	It is defined in IEEE 802.16e [2] that an MCID is 12 bits over the R1 interface.
>> MCID Reservation Result	6.2.2.14	M	Indicate the MCID reservation result

2

3 **4.2.6.3 Error Handling During MCBCS Data Path Release**

4 **4.2.6.3.1 Timers and Timing Considerations**

5 This section identifies the timer that the entities participating in the MCBCS Data Path Release procedure SHALL
 6 use. MCBCS Data Path Release procedure utilizes one timer:

- 7 1. $T_{R6_MBS_Path_DeReg}$: is started by a MBS DPF upon sending *R6_MBS_Path_DeReg_Req*. It is stopped
 8 upon receiving a corresponding *R6_MBS_Path_DeReg_Rsp*.

9

10 Table 4-20 shows the default value of timer and also indicates the range of the recommended duration of the timer.

11

Table 4-20 - Timer Values for MBS Path Release Procedure

Timer	Default Values (msec)	Criteria	Maximum Timer Value (msec)
$T_{R6_MBS_Path_DeReg}$	1000	100ms	25500

12

1 **4.2.6.3.2 Handling Error Conditions**

2 Table 4-21 lists the behavior for various error conditions during MCBCS Data Path Release.

3 **Table 4-21 - MCBCS Data Path Release – Handling Error Conditions**

	Failure Case	Action
1	A response message doesn't matching to a sent request message (e.g. if MBS Zone ID or MCID or ContentsID or Transaction ID of a response message doesn't match to a sent request message.).	<ul style="list-style-type: none"> The receiver SHALL silently discard the response message.
2	MBS DPF doesn't receive <i>R6_MBS_Path_DeReg_Rsp</i> from BS.	<ul style="list-style-type: none"> MBS DPF SHALL retransmit <i>R6_MBS_Path_DeReg_Req</i> with the same transaction ID until max of retransmission if $T_{R6_MBS_Path_DeReq}$ is expired. If $T_{R6_MBS_Path_DeReq}$ is expired after maximum number of retransmissions, MBS DPF releases the data path of the contents for the BS.
3	MBS Proxy receives invalid <i>R3_Session_Rel_Req</i> .	<ul style="list-style-type: none"> MBS Proxy SHALL send <i>R3_Session_Rel_Rsp</i> with an appropriate failure indication value. MCBCS Server doesn't retransmit <i>R3_Session_Rel_Req</i>.
4	BS receives invalid <i>R6_MBS_Path_DeReg_Req</i> .	<ul style="list-style-type: none"> BS SHALL send <i>R6_MBS_Path_DeReg_Rsp</i> with an appropriate failure indication value. MBS DPF doesn't retransmit <i>R6_MBS_Path_DeReg_Req</i> and releases the data path information of the content for the BS.

4
 5 **4.2.6.3.3 Timer Expiry**

6 Table 4-22 shows the details of corresponding actions upon timer expiry. Upon each timer expiry, if the number
 7 of retries has not exceeded the maximum, the timer is restarted. Otherwise, the corresponding action(s) should be
 8 performed as indicated in 4.2.6.3.1.

9 **Table 4-22 - Timer Max Retry Conditions**

Timer	Entity where Timer Started	Action(s)
$T_{R6_MBS_Path_DeReg}$	ASN-GW (MBS DPF)	If this timer expires after max retry, MBS DPF releases the data path for the BS.

10
 11

1 **4.2.7 Leaving Service**

2

3 When the MS completes the reception of the particular MBS content or it wants to end the reception of the particular
4 MBS content, it performs the Leaving procedure in MS internally. In broadcast and static multicast services , IGMP
5 leave for IPv4, or a MLD done/report for IPv6, from MS to ASN-GW is not required. For the dynamic multicast, the
6 distribution tree is released based on the presence of other users/viewers within the BS.

1
2
3
4
5
6
7
8
9
10
11
12
13
14
15
16
17
18
19

4.2.8 Delivery Confirmation and Unicast Retransmission

Figure 4-9 describes the Delivery Confirmation procedure.

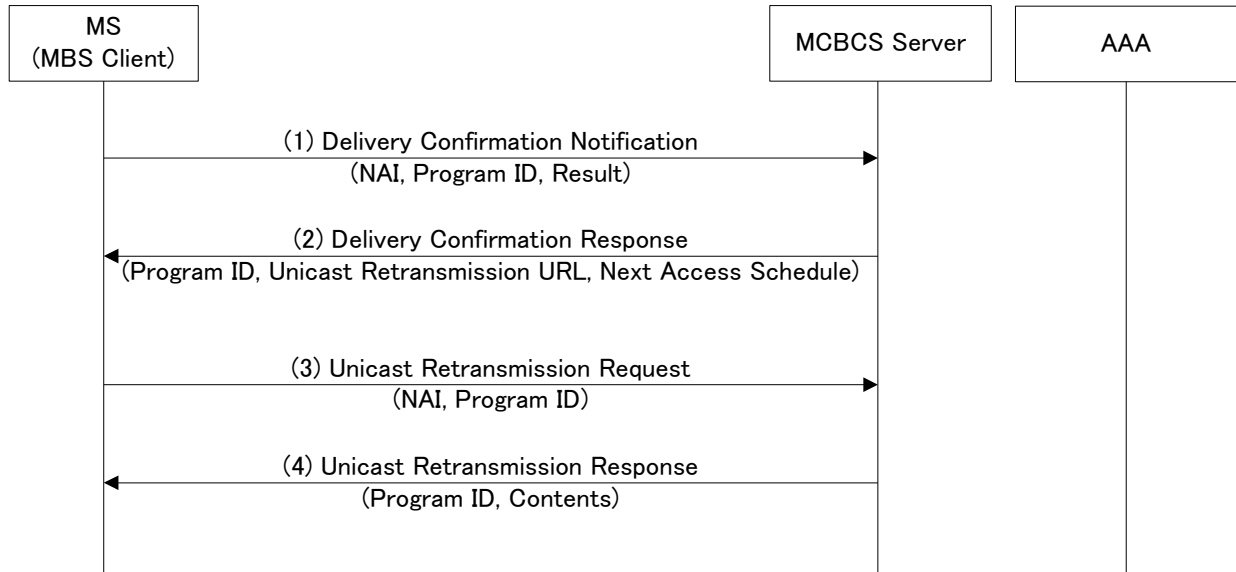

Figure 4-9 - Delivery Confirmation Procedure

STEP 1

The MS notifies the result of the contents reception by sending Delivery Confirmation Notification message to the MCBCS Server.

STEP 2

The MCBCS Server sends Delivery Confirmation Response to the MS.
When the unicast retransmission is possible, Unicast Retransmission URL is returned.

STEP 3

The MS requests the Unicast Retransmission.

STEP 4

Contents are retransmitted.

1 **4.2.8.1 Combined Message IEs**

2 **Table 4-23 - Delivery Confirmation Notification**

IE	Reference	M/O	Notes
User Information		M	NAI (Username (NAI) during Step1 is not necessarily the NAI used for User/Device Authentication during WiMAX network access authentication.)
Results		M	
>Program ID		M	
>Contents Specification		M	
>>Delivery Result		M	OK/NG OK: File Downloading -> All data was able to be received. Streaming -> Everything was received or part was received. NG : All other than OK (e.g. MS terminated abnormally while receiving it. The user canceled intentionally while receiving it.)
>>Reception Date and Time		M	File Downloading -> At the reception completion date and time. Streaming -> At the reception start date and time.
>>NG Reason		O	This element shall contain the NG reason for Delivery.

3

4 **Table 4-24 - Delivery Confirmation Response**

IE	Reference	M/O	Notes
Results		M	
>Program ID		M	ID at Request is set.
>Result		M	OK/NG

IE	Reference	M/O	Notes
>NG Reason		O	This element shall contain the NG reason for Delivery Confirmation Notification. The NG reason is specified as follows: 1. Authorization has failed. 2. Requested program is not available. 3. Unknown Reason.
>Unicast Retransmission URL		O	When multicast delivery fails, MS can download it from this URL.
Next Access Schedule		O	The MS shall send Delivery Confirmation Notification at this date and time. (It will send it again by the unicast though it differs according to contents when the reception is NG when MS receives contents by the multicast. It is thought that the possibility that the network and MCBCS Server crowd is very high because traffic is explosively generated if MS demands the unicast sending again from MCBCS Server all together immediately after the multicast. Therefore, time when the unicast retransmission is done is specified for each MS to level the traffic explosively generated, and MS makes it access MCBCS Server at the specified time. The time that comes for the access from MS to MCBCS Server including this unicast retransmission is assumed to be Next Access Schedule.)

1

2

Table 4-25 - Unicast Retransmission Request

IE	Reference	M/O	Notes
User Information		M	NAI (Username (NAI) during Step1 is not necessarily the NAI used for User/Device Authentication during WiMAX network access authentication.)
Program ID		M	

3

4

Table 4-26 - Unicast Retransmission Response

IE	Reference	M/O	Notes
Results		M	

IE	Reference	M/O	Notes
>Program ID		M	ID at Request is set.
>Result		M	OK/NG
>NG Reason		O	This element shall contain the NG reason for Unicast Retransmission. The NG reason is specified as follows: 1. Authorization has failed. 2. Requested program is not available. 3. Unknown Reason.

1
2
3

4.3 Mobility Management

5 Inter-MBS zone mobility is supported based on the following two operations.

6 First, the MS SHALL detect the MBS Zone ID list of the serving BS by monitoring a DCD (or MBS_MAP_IE)
7 MAC message and the MBS Zone ID list of neighbor BS(s) by monitoring a MOB_NBR-ADV message, while it
8 detects MCID by reading the broadcasted MBS_MAP message for multi-BS MBS and the broadcasted
9 MBS_MAP_IE message for single-BS MBS.

10 Second, the application client program manages the mapping information between MAC layer ID (MCID, MBS
11 zone ID) and application layer channel ID. If a channel is broadcasted in multiple MBS zones, then the multiple pair
12 of (MCID and MBS zone ID) will be downloaded to MAC layer of MS when the channel is selected by the User.

13 So, the additional operation between MS and BS for inter-MBS Zone mobility support is not required because the
14 MS has already obtained the mapping information for the target MBS Zone.

15 How the client program obtains the mapping information is shown in section 4.2.1 and 4.2.2

16

4.4 Power Saving Support

18 The main requirement of power saving is to minimize the uplink signaling from MS that requires instantaneously
19 large power consumption. Since the MCBCS-application layer signaling method requires no interaction between MS
20 and BS for both channel change and inter-MBS zone mobility, it fully meets the requirement for power saving.

21

22 Another requirement to consider is to reduce the time duration of keeping modem on, which depends on MS's
23 implementation, signaling overhead (e.g. size, frequency) and transmission cycle of MBS data bursts.

24 The maximum transmission cycle of MBS data burst is 256 frames according to IEEE 802.16 specifications (Next
25 MBS Frame Offset). In order to include both MBS_MAP message and MBS data bursts in the same downlink
26 subframe, it is necessary to limit the transmission cycle up to 5 frames since MBS burst frame offset indicates only
27 2~5 frames.

28 Note: According to service type (e.g. Audio, live streaming), the transmission cycle can be beyond 5 frames.

29

4.4.1 Mobile Station operation for MCBCS

Idle mode operation for MCBCS is different from idle mode operation for Unicast since the MS may continue receiving downlink data bursts while in idle mode.

MS in idle or sleep mode should be able to continue receiving MBS data bursts. To this end, the MS may need to turn on its modem before any reception of MBS data bursts of the channel selected by the User, regardless of paging cycle or sleep window cycle specified in IEEE 802.16 document.

4.5 Security

A security function may be used to protect user information and the MCBCS data and to authenticate the user with the MCBCS server. The security function is needed in the following cases.

- The user subscribes to the program (protect user information and authenticate user)
- Transmission of MCBCS data (protect MCBCS data)

In subscription of user's program, user information is protected by using SSL/TLS[11] for example. Additionally, this authentication of the user with MCBCS Server serves to control illegal usage.

4.5.1 Group Management

The MCBCS Server shall manage group management for MCBCS service. When user subscribes program(s) for MCBCS, the MCBCS Server shall authenticate the user and provides all necessary security information such as encryption key, lifetime and etc. In the case of free or public contents delivery, the MCBCS Server may not manage group management for security.

4.5.1.1 Group Management Procedures

User sends user information to MCBCS Server after encryption establishment over IP between MS and MCBCS Server. MCBCS Server sends user information to AAA server to authenticate user information using MS CHAPv2 for example. Authentication, Authorization, and Accounting protocol depend on operators policy (out of scope).

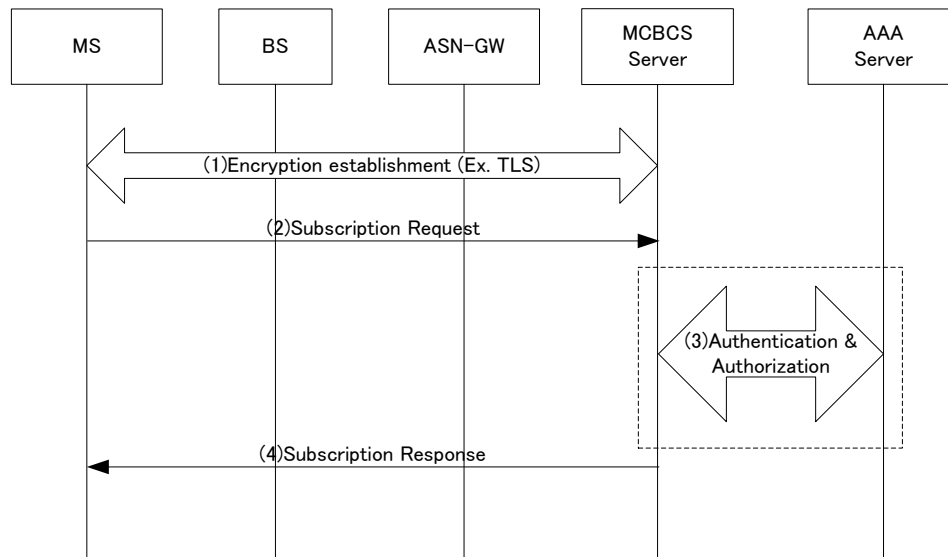

Figure 4-10 - Group Management Procedures (Example)

1 **STEP 1**

2 After Service Guide Acquisition, MS shall establish encrypted connection [10] between MS and MCBCS Server. In
3 case of free or public contents, this step may be omitted.

4

5 **STEP 2**

6 Refer to 4.2.2.1.

7

8 **STEP 3**

9 MCBCS Server shall send user information to AAA server. The authentication protocol depends on operator's
10 policy such as EAP-TTLS/TLS or MS-CHAP-V2.

11

12 **STEP 4**

13 Refer to 4.2.2.1

14

15 **4.5.2 Session Management**

16 The MCBCS Server shall manage session management for MCBCS service. When the MCBCS Server needs to
17 start program(s), the MCBCS Server starts session including necessary security information. The MCBCS Server
18 also stops the session. In the case of free or public contents delivery, MCBCS Server may not manage session
19 management for security.

20

21 **4.5.2.1 Session Management mechanism**

22 MCBCS Server shall include security information in Subscription Response message if content is encrypted. The
23 security information may include encryption mechanism, encryption key and so on. MCBCS Server shall manage
24 unique security information per content. The encryption mechanism is basically application level encryption (out of
25 scope).

26

27 **4.6 MCBCS QoS**

28 MCBCS connections are shared by many users so that their transmission rate and latency do not depend on users,
29 while the unicast service flows (SFs) are unique per user, i.e., the same class of QoS SF per user can have different
30 QoS parameter values depending on user class. This main difference makes QoS management for MCBCS different
31 from that for the unicast service as follows.

32 The air scheduling parameters for supporting the per-flow QoS of the unicast service are determined dynamically
33 per MS based on each MS's channel information via CQICH, but those for supporting MCBCS QoS shall be
34 configured by NAP in advance based on NSP's requirements on channel composition and schedule. Thus, a MCBCS
35 connection has a single QoS requirement independently of user classes.

36 Basic MBS air scheduling parameters for MCBCS QoS are DIUC, Repetition coding indication, Next MBS frame
37 offset, Number of OFDMA symbols, Number of Subchannels. These parameters determine the air transmission rate
38 and latency of each MBS data burst.

39 MCBCS traffic has the highest priority among the bearer traffic sharing the same downlink subframe. However,
40 QoS of the admitted unicast QoS SFs should also be guaranteed when DL subframe is shared by MCBCS. In order
41 to do that, it is better to fix and separate MBS region, i.e., MBS permutation zone from the permutation zone for the
42 unicast service traffic.

1 Since this document does not require DSx method for MCBCS connection setup/release, neither PCRF/PDF nor
2 AAA is required to decide MCBCS QoS policy.

3

4 **4.7 Accounting**

5 The network system supports subscription based accounting, traffic based accounting, time based accounting, or
6 content grade based accounting. Moreover, the accounting type can be flat rate or charge-free. Which accounting
7 type shall be applied is based on operator's policy.

8 Accounting client shall be located at MCBCS Server.

9 The accounting client in MCBCS Server collects accounting related information and reports it to AAA, and AAA
10 manages the accounting information.

11 In the charge-free case, accounting procedure between MCBCS Server and AAA may not be needed.

12 This section describes RADIUS [20] based accounting procedure, but Diameter [21] based procedure or other
13 proprietary protocol also can be used. Which protocol will be applied is based on operator policy. Since the
14 interface between MCBCS server and AAA is a CSN internal interface, the detail procedure (i.e. message format,
15 timer definition, error handling) is outside the scope of this document.

16

17 **4.7.1 Subscription Based Accounting**

18 In the subscription based accounting case, MCBCS server reports the accounting information to AAA when the user
19 completes the subscription. The Figure 4-11 shows an example of this case.

20

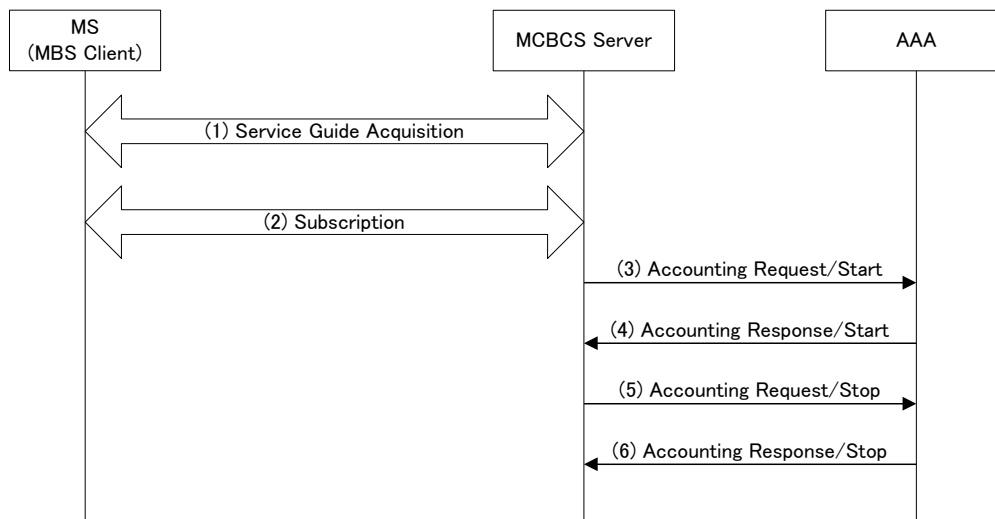

21

22 **Figure 4-11 - Call Flow for Subscription Based Accounting**

23

24 **STEP 1**

25 MS gets service guide of MCBCS service from MCBCS Server via Broadcast or Unicast manner.

26 **STEP 2**

27 MS requests the subscription of the desired content based on the service guide acquired in step1. If authentication
28 and authorization of the subscription succeed, the MCBCS Server sends the response to MS with a mapping table
29 for receiving contents.

1 **STEP 3-6**

2 If the subscription succeeds, MCBCS Server starts *Accounting Request/Response* procedure between MCBCS
3 Server and AAA in order to inform AAA of accounting information.

4

5 Figure 4-11 shows an example using RADIUS protocol. However, RADIUS is generally used for measured rate
6 charging. Therefore, in subscription based accounting case, the charging may be performed internally by AAA
7 when subscription authentication, or using proprietary interface between MCBCS Server and AAA.

8

9 Flat rate accounting can be considered as a special case of subscription based accounting, which AAA does not
10 calculate charging amount every time.

11 Different rates based on content grades shall be supported for content grade accounting.

12

13 **4.7.2 Traffic Based Accounting**

14 In the traffic based accounting case, MCBCS server reports the accounting information to AAA based on the traffic
15 amount sent by MCBCS Server or the delivery confirmation message from MS. Figure 4-12 shows an example of
16 this case.

17

18

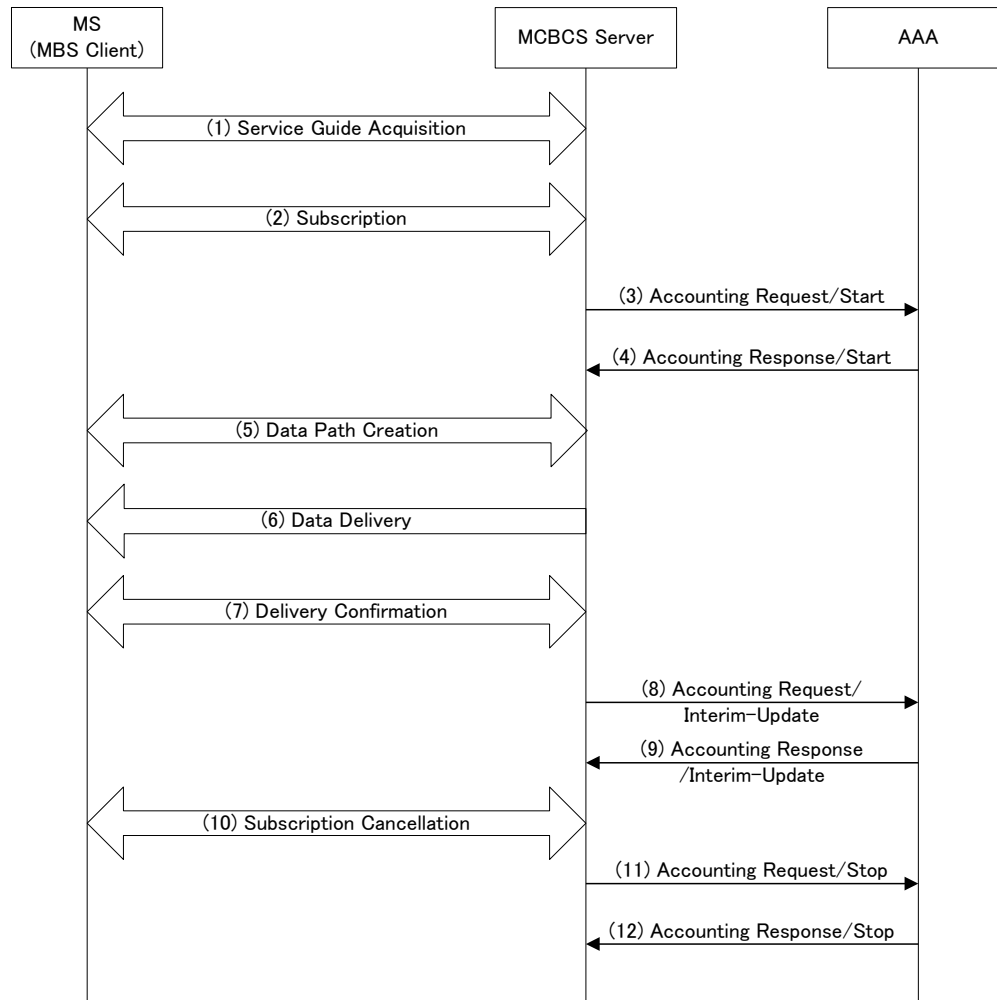

Figure 4-12 - Call Flow for Traffic Based Accounting

1
2
3
4
5
6
7
8
9
10
11
12
13
14
15
16
17

STEP 1 ~ 2

The procedure is the same as subscription based accounting case.

STEP 3~4

MCBCS Server starts Accounting Start procedure between MCBCS Server and AAA.

STEP 5

Before content delivery, the logical data path for MCBCS is created between MS and MCBCS Server.

STEP 6

After logical data path establishment, the content is delivered from MCBCS Server to the MS.

STEP 7

After completion of content delivery or when MS stops receiving the content before content delivery finishes, the MS sends Delivery Confirmation to MCBCS Server to report the delivery status (e.g. the contents reception is failed or succeeded) and traffic quantity information (e.g. the size received, the number of packets received etc.).

This procedure is optional. If this procedure is omitted, MCBCS Server should calculate the traffic quantity based on its own mechanism which is outside the scope of this document.

1 **STEP 8~9**

2 Based on the traffic amount calculated by MCBCS Server or the traffic quantity information in Delivery
3 Confirmation from MS, MCBCS Server starts Accounting Update procedure in order to inform AAA of the latest
4 accounting information.

5 Step5 ~ 9 can be repeated while the content delivery is repeated.

6 **STEP 10**

7 MS cancels the subscription. This procedure is triggered by user's operation.

8 **STEP 11~12**

9 MCBCS Server starts Accounting Stop procedure with AAA.

10

11 **4.7.3 Time Based Accounting**

12 In the time based accounting case, MCBCS server reports the accounting information to AAA based on the time that
13 the MS has spent receiving the service. The procedure of time based accounting is the same as traffic based
14 accounting. The only difference is that after completion of content delivery or when MS stops receiving the content
15 before content delivery finishes, MS includes the time duration that the MS has been receiving the service instead of
16 traffic amount quantity in Delivery Confirmation in STEP 7 in Figure 4-12.

17 And also, if Delivery Confirmation is omitted, MCBCS Server should calculate the time duration based on its own
18 mechanism which is outside the scope of this document.

19

20 **4.8 Roaming Support**

21 Roaming support for MCBCS will be considered in phase 2 as determined by MCBCS subteam.

22 **4.9 MCBCS Network Resource Management**

23 For the efficient usage of network resource for MCBCS, it is necessary to reduce unnecessary signaling and, if
24 needed, the size of signaling for three main MCBCS features.

25 For the mapping information delivery, MCBCS-application layer signaling solution reuses the existing service guide
26 acquisition or subscription procedure and has no impact on all reference interfaces defined in WiMAX forum

27

28 For synchronization, the method in section 3.4 does not require any signaling for delivery of GRE key information
29 and the sync information over R6 interfaces unlike Unicast.

30

31 For data path setup and release, the procedure in section 4.2.5 and 4.2.6 has the following merits for efficient usage:

- 32
- 33 ■ It has no impact on R1 interface signaling.
 - 34 ■ Unlike the Path_Reg/Mod/DeReg procedure, it does not require an acknowledgement signaling since GRE
35 key of each MCBCS connection is not MS-unique but is determined automatically with the pair of (MBS
zone ID, MCID).
 - 36 ■ Multicast transport is used over R6 interface to cover numerous BSs
 - 37 ■ Multicast IP over R6 interface has one-to-one mapping to MBS zone ID (not to MCID) so that IGMP for
38 IPv4 / MLD for IPv6 procedure over R6 interface is minimized

39

40

1 **4.9.1 MCBCS Radio Resource Management**

2 Here, we assume that a single subcell (1 carrier 1 sector) is shared by unicast service and MCBCS.

3 Then, we consider two points for radio resource management for MCBCS: how to guarantee QoS of both unicast
4 and MCBCS traffic; and how to use the radio resources efficiently without increasing scheduling complexity.

5 For guaranteeing QoS of the admitted unicast service flows, the physical air resource portion for MCBCS should not
6 be increased dynamically so that the physical air resource for unicast traffic is not reduced. On the other hand, it
7 should not be decreased dynamically under the same channel composition for guaranteeing QoS of MCBCS traffic.

8 The physical air resource portion and/or air parameters for MCBCS should be configured by the operator.

9 Thus, the repeated MBS region (i.e., MBS permutation zone) within a single MBS zone should be fixed when the
10 channel composition is not changed, although a single MBS zone can have several types of MBS regions with
11 different sizes.

12 For the efficient radio resource allocation, we consider the following example for how to allocate MBS region when
13 the radio resource portion for MCBCS is determined. Let's assume that 33% of physical radio resource is allocated
14 for MCBCS traffic. Then, there are various ways of allocation. We can allocate 33% of radio resource every DL
15 subframe to MCBCS or the overall DL subframe every three DL subframes to MCBCS. Since MBS_MAP_IE and
16 MBS_MAP MAC messages should be broadcasted with MBS data bursts, the later method will be much better than
17 the former one.

19 **4.9.2 Multi-BS Transmission Synchronization**

20 MCBCS content is delivered to BSs within the MBS Zone according to the mechanism described in section 3.4.
21 And BSs transports the content over the air link according to the mechanism described in section 3.5. Based on the
22 above, synchronization of Multi-BS transmission can be realized.

24 **4.10 Transport Mechanism for Content Delivery**

25 **4.10.1 Via Unicast**

26 MCBCS server may transmit the content to MS via the unicast service flow of the user if it receives a retransmission
27 request from the MS. For detail, see section 4.2.8.

29 When there is one MS or few MSs who wants to receive the content in the MBS Zone, the content may be delivered
30 using unicast service flow of the MS(s) instead of using multicast or broadcast service flow. More details of this
31 case will be discussed in phase2.

32 In roaming case, the content may be delivered to the roaming MS using unicast service flow. More details of this
33 case will be discussed in phase2.

35 **4.10.2 Via Multicast and Broadcast**

36 In the general case, the content is delivered to MSs using multicast or broadcast service flow.

37 The content delivery from MCBCS Server to BSs in the MBS Zone is performed via a data path using IP multicast
38 mechanism. And the delivery from BSs to MSs is performed via MBS permutation zone of air frame. For more
39 details, refer to section 3.

5. Generic Procedures to support the Data Transfer

5.1 Real time data transfer over Broadcast Channel

5.1.1 Protocol stack

There is no dedicated protocol stack for the real time data transfer. The protocol stack is the same as described in Figure 3-2.

5.1.2 Procedures for real time data transfer over Broadcast Channel

NAP previously configures parameters of MBS_MAP_IE, MBS_MAP and MBS region such as DIUC, repetition coding indication, permutation, boosting, Permbase_ID, PRBS_ID, Next MBS frame offset, upper bound of MBS region MBS burst size. Especially in the case of real time data transfer, these parameters need to be configured to be able to support the delivery rate that the application needs.

Before contents delivery, MCBCS Server sends *R3_Session_Start_Req* message to ASN-GW in order to indicate MCBCS data path setup. Upon receiving the message, ASN-GW performs IGMP join for IPv4 / MLD report for IPv6 procedure to the multicast router between ASN-GW and MCBCS server to setup R3 data path, and R6 data path setup with BSs belonging to the MBS Zone. BS performs IGMP join for IPv4 / MLD report for IPv6 procedure to the multicast router between BS and ASN-GW. R3 and R6 path setup shall be finished before contents delivery. Whether MCBCS server will abandon the content delivery when the data path setup was failed with some of BSs under the MBS Zone, is based on an operator policy.

When contents transmission start time comes, MCBCS Server starts the transmission of the contents packet. The IP packet transmitted on the R3 uses the multicast IP address that MS will eventually receive.

The bearer path transport procedure from MCBCS Server to MS is described in section 3.

MS gets the delivery start time of the content during service guide acquisition, and MS can begin to receive MBS burst at the delivery start time.

5.2 Non Real time data transfer over Broadcast Channel

5.2.1 Protocol stack

There is no dedicated protocol stack for the non real time data transfer. The protocol stack is the same as described in Figure 3-2.

5.2.2 Procedures for non real time data transfer over Broadcast Channel

The procedure for non real time data transfer is the same as the real time data transfer case described in section 5.1.2.

5.3 Non scheduled data transfer over Broadcast Channel

1 **5.3.1 Protocol stack**

2 There is no dedicated protocol stack for the non scheduled data transfer. The protocol stack is the same as described
3 in Figure 3-2.

4

5 **5.3.2 Procedures for non scheduled data transfer over Broadcast Channel**

6 Also for non scheduled data transfer, NAP previously configures all parameters of MBS_MAP_IE, MBS_MAP and
7 MBS region such as DIUC, repetition coding indication, permutation, boosting, Permbase_ID, PRBS_ID, Next
8 MBS frame offset, and the size and location of the MBS burst size in DL subframe. In case of single-BS MBS,
9 MBS_MAP and MBS region will not be used.

10 The data path setup procedure and the data transfer procedure between MCBCS Server and BS are the same as the
11 scheduled data transfer case (e.g. section 5.1.2, 5.2.2). However, MS doesn't get the contents delivery start time
12 previously because of non scheduled data so that it is necessary to specify a specific MCID for the non-scheduled
13 MCBCS channel. The non scheduled data transfer is performed as follows. We need a further study on stage2 and 3
14 level specifications to support this feature.

15

16 **5.3.2.1 Idle Mode MCBCS Support with Alert**

17 Alert for non-scheduled MCBCS traffic shall be transmitted in advance during PLI (Paging Listening Interval),
18 which notifies the scheduling information for the non-scheduled MCBCS traffic.

19

20 **5.3.2.2 Sleep Mode MCBCS Support with Alert**

21 Alert for non-scheduled MCBCS traffic shall be transmitted in advance during Listening Window, which notifies
22 the scheduling information for the non-scheduled MCBCS traffic.

23

6. Message and Parameter Definitions

6.1 Message Definitions and Construction Rule

The following provides guidance for constructing and documenting a message definition.

1. A child TLV SHALL NOT appear in a message definition without its parent TLV also appearing in the message definition.
2. If a child TLV that is optional in the parent's TLV definition appears as Mandatory in a message definition, then its parent TLV SHALL also appear as Mandatory in the message definition.
3. If a parent TLV appears as Mandatory in a message definition, all of its Mandatory child TLVs (as shown in the parent TLV definition) SHALL also appear as Mandatory in the message definition.
4. If a parent TLV appears as Optional in a message definition, all of its Mandatory child TLVs (as shown in the parent TLV definition) shall appear as Conditional Mandatory in the message definition. Each of these child TLVs shall include the note: This TLV SHALL be included if the *insert name of parent TLV* is included in the transmitted message.

Chapter 6 describes R3/R6 related information, but not include R2 related information in order to avoid the confusion. R2 message format is XML type of message.

Table 6-1 shows function and message types related to MCBCS feature.

Table 6-1 - Function and Message Types Index

Function Type	Msg Type	Message	Message Layout
13 (MCBCS Application Layer approach)	1	R6_MBS_Path_Reg_Req	Table 4-7
	2	R6_MBS_Path_Reg_Rsp	Table 4-8
	3	R6_MBS_Path_DeReg_Req	Table 4-16
	4	R6_MBS_Path_DeReg_Rsp	Table 4-17
	5	R3_Session_Start_Req	Table 4-9
	6	R3_Session_Start_Rsp	Table 4-10
	7	R3_Session_Release_Req	Table 4-18
	8	R3_Session_Release_Rsp	Table 4-19
	9	R3_Session_Failure_Ind	Table 4-11
	10	R3_Session_Failure_Ack	Table 4-12

1 **6.2 TLV Definitions**

2 **6.2.1 TLV Format**

3 TLV format is complied with section 5.3 of WiMAX Forum Network Architecture (Stage3); Version 1.5 [5].

4 **6.2.2 TLV Encoding**

5 **6.2.2.1 Contents ID**

Type	470
Length in octets	2
Value	
Description	A Contents ID uniquely identifies MBS contents in MBS Server. One Contents ID is mapped to one R3 IP Multicast Address. It is the same as MBS Contents ID defined in IEEE 802.16e [2].
Parent TLV(s)	Contents Info

6

7 **6.2.2.2 Contents Info**

Type	471	
Length in octets	Variable	
Value	Compound	
Description	Information about MBS contents. It could be multiple.	
Elements (Sub-TLVs)	TLV Name	M/O
	Contents ID	M
	MCID	M
	Contents IP	O[Note1]
	Contents Type	O[Note2]
	GRE KEY	O
	Delivery Start Time	O[Note2]
	Delivery End Time	O[Note2]
MCID Reservation Result	M	
Parent TLV(s)	MBS Zone Info	

8

9 [Note 1] When Contents Info TLV is used in *R3_Sesssion_Start_Req*, this sub TLV is mandatory.

10 [Note 2] When Contents Info TLV is used in *R3_Sesssion_Start_Req* and *R6_MBS_Path_Reg_Req*, this sub TLV is
 11 mandatory.

12

13 **6.2.2.3 Contents IP**

Type	472
-------------	-----

Length in octets	Variable (either 4 or 16 octets)
Value	The Identifier might be in format of either 4-octet IPv4 Address or 16-octet IPv6 Address. The length defines also the format of the Identifier.
Description	R3 Multicast IP Address for Contents
Parent TLV(s)	Contents Info

1

2 **6.2.2.4 Contents Type**

Type	473
Length in octets	1
Value	0x1 indicate pre-scheduled service 0x2 indicate non-scheduled without alert 0x3 indicate non-scheduled with alert
Description	Indicate the service type.
Parent TLV(s)	Contents Info

3

4 **6.2.2.5 Delivery End Time**

Type	474
Length in octets	4
Value	tv_sec field of gettimeofday()
Description	Indicate MBS bust transfer end time at base station.
Parent TLV(s)	Contents Info

5

6 **6.2.2.6 Delivery Start Time**

Type	475
Length in octets	4
Value	tv_sec field of gettimeofday()
Description	Indicate MBS bust transfer start time at base station.
Parent TLV(s)	Contents Info

7

8 **6.2.2.7 GRE Key**

Type	476
Length in octets	4
Value	GRE Key : (MBS Zone ID, MCID)=1:1
Description	After packetization, the fragmented/packed packet is encapsulated by GRE header and transferred to BSs on R4/R6. GRE KEY field in GRE header consists of MBS Zone ID and MCID. The Key shall be used to identify the content on the R4/R6.

Parent TLV(s)	Contents Info
----------------------	---------------

1

2 **6.2.2.8 MBS Zone ID**

Type	477
Length in octets	1
Value	MBS Zone ID is 7 bits. The MSB of MBS Zone ID is 0.
Description	This is defined in IEEE 802.16e [2]. One MBS Zone consists of one or more BSs. MBS Zone ID = 0 shall not be used.
Parent TLV(s)	MBS Zone Info

3

4 **6.2.2.9 MBS Zone Info**

Type	478	
Length in octets	Variable	
Value	Compound	
Description	Information about MBS Zone. It could be multiple.	
Elements (Sub-TLVs)	TLV Name	M/O
	MBS Zone ID	M
	Contents Info	M
	R6 Multicast IP	O[Note1]
	MBS DPF ID	M
	Macrodiversity-enabled	O
Message Primitives That Use This TLV	R3_Session_Start_Req, R3_Session_Start_Rsp R3_Session_Rel_Req, R3_Session_Rel_Rsp R3_Session_Failuer_Ind, R3_Session_Failure_Ack R6_MBS_Path_Reg_Req, R6_MBS_Path_Reg_Rsp R6_MBS_Path_Dereg_Req, R6_MBS_Path_Dereg_Rsp	

5

6 [Note 1] When MBS Zone Info TLV is used in *R6_MBS_Path_Reg_Req*, this sub TLV is mandatory.

7

8 **6.2.2.10 MCID**

Type	479
Length in octets	2
Value	0xFEAE0 - 0xFEFE
Description	It is defined in IEEE 802.16e that an MCID is 12 bits over the R1 interface.
Parent TLV(s)	MBS Zone Info

9

1 **6.2.2.11 R6 Multicast IP**

Type	480
Length in octets	Variable (either 4 or 16 octets)
Value	The Address might be in format of either 4-octet IPv4 Address, or 16-octet IPv6 Address. The length defines also the format of the Address.
Description	Multicast IP address for establishing multicast connection between ASN-GW and BS(s).
Parent TLV(s)	MBS Zone Info

2 **6.2.2.12 MBS DPF ID**

Type	481
Length in octets	Variable (could be of three fixed sized: 4, 6 and 16 octets)
Value	The identifier might be in format of either 4-octet IPv4 Address, 6-octet IEEE 802.16 BS ID or 16-octet IPv6 Address. The length defines also the format of the Identifier.
Description	Unique identifier for the MBS Data Path Function network entity, which administers the MBS data distribution and Packetization within MBS Zone.
Parent TLV(S)	MBS Zone Info

3

4 **6.2.2.13 Macrodiversity-enabled**

Type	482
Length in octets	1
Value	Enumerator. The values are: 0x01 Not enabled 0x02 Enabled All other values are reserved.
Description	Indicate whether or not a MBS Zone is macrodiversity-enabled
Parent TLV(S)	MBS Zone Info

5

6 **6.2.2.14 MCID Reservation Result**

Type	483
Length in octets	1
Value	Enumerator. The values are: 0x00 = Success 0x01 = Failure All other values are reserved.
Description	Indicate the MCID reservation result
Parent TLV(S)	Contents Info

7

8

1
2